

Bulletin 1694 Electronic circuit protection for 24V DC with IO-Link



WARNING: Electrostatically sensitive sub-assemblies can be destroyed by voltages far below the human perception threshold. These voltages already occur if you touch a component or electrical terminals of a sub-assembly without being electrostatically discharged. The damage of a sub-assembly caused by an overvoltage is often not immediately recognised, but will be noticed only after a longer operating time.

Mounting or actuation of the 1694 connector arm must only be effected at dead-voltage. For start-up the 1694 connector arm must be closed.

Device to be installed, operated and maintained by trained personnel only.

To secure device properly against unintended access, product shall be mounted in locked cabinet.

The device can't be serviced or repaired.

Do not open device's enclosure.

Table of contents

1.	Bulletin 1694 Electronic circuit protection modules for 24V DC with IO-Link communication	2
1.1.	1694-PMD* and 1694-PMD2A10 Circuit Protection Module Technical data	3
2.	Bulletin 1694. Power Feed 1694-PFD1244 with IO-link communication	8
2.1.	1694-PFD1244 Power Feed Module Technical data	9
3.	IO-Link technology review	15
3.1.	Accessing IO-Link Data	16
4.	IO-Link connector description used for 1694-PFD1244	16
5.	Signaling of operating status on 1694-PFD1244 Power Feed Module	17
6.	Signaling of operating status on 1694-PMD* Protection Modules	18
7.	Installation and configuration of 1694-PFD1244 and 1694-PMD* in Studio5000	19
7.1.	AOP Installation	19
7.2.	Creating a Project	19
7.3.	Adding a Controller	19
7.4.	Adding a Point IO (Ethernet Adapter)	20
7.5.	Adding an IO-Link Master	21
7.6.	Registration of IODD file for Power Feed 1694-PFD1244	23
7.7.	Connect the 1694-PFD1224 to the IO-Link Master	25
7.8.	Download the Project to PLC	26
7.9.	Exploring the 1694-PMD1244 Parameters in AOP	28
7.9.1.	Common Tab	30
7.9.2.	Identification Tab	31
7.9.3.	Observation Tab	32
7.9.4.	Parameters Tab	34
7.9.5.	Diagnosis Tab	36
8.	Device Parameters Details	39
8.1.	Cyclic Data	39
8.2.	Non-Cyclic Data	43
9.	Rockwell Automation Support	47

1. Bulletin 1694 Electronic circuit protection modules for 24V DC with IO-Link communication

Bulletin 1694 Electronic Circuit Protection is a modular solution with a max. system capacity of 40A. The protection modules come in fix and adjustable current rating in a range from 1A...10A. Designed for 24V DC circuits, the 1694 provides comprehensive protection against short circuit and overcurrent conditions while allowing for inrush current. 1694-PMD* and 1694-PFD1244 Provides IO-Link communication capability.

Basic trip curve and schematic diagram 1694-PMD

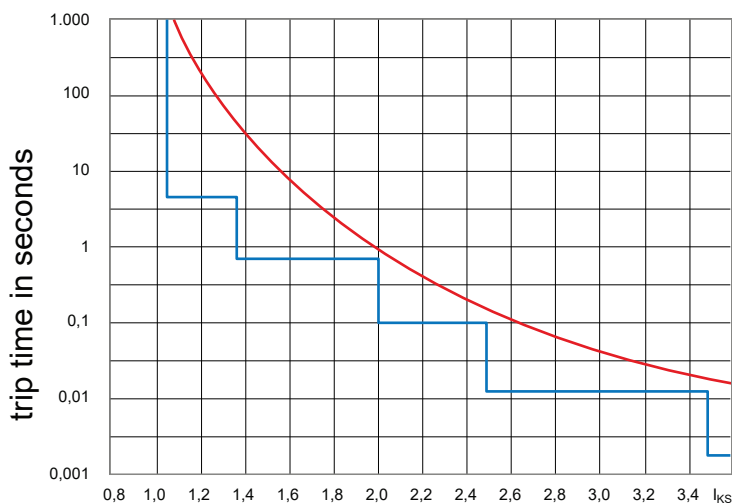

times rated current trip curve

Schematic diagram

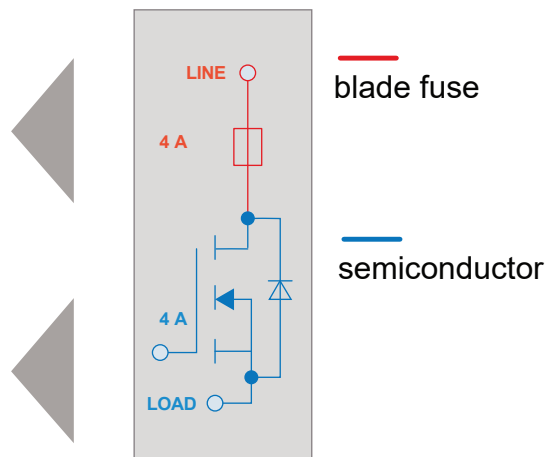

Features

- Combination of supply modules, circuit protection and power distribution
- IO-Link communication to PLC via Power Feed 1694-PFD1244 module. Main features:
 - Current and Voltage monitoring,
 - Statistics,
 - Remote control,
 - Error messaging.
- Selective load protection by means of electronic trip curve
- No accessories required for connecting the modules
- Width per channel only 12.5 mm (1-channel) or 6.25mm (2-channel)
- Integral fail-safe element, adjusted to current rating
- Switching capacitive loads up to 20,000 μ F (at $I_N > 6A$)
- Manual ON/OFF/reset momentary switch
- Clear status indication by means of LED and auxiliary contact (1694-PF power feed module)
- Wire connection via push-in terminals
- 1694-PMD* available in Class 2 version in nominal currents: 1A, 2A, 3A, 4A
- Adjustable circuit protection module 1694-PMD2A10 with trip current range from 1A to 10A.

Notes

- Connection to a higher or not reliably disconnected voltage can cause hazardous conditions or damages
- Only the intended Bulletin 1694 circuit protectors must be used
- The technical data of the circuit protectors used must be observed
- The entire power distribution system must only be installed by qualified personnel
- Only after expert installation must the device be supplied with power
- After tripping of the circuit protector and before reset, the cause of the anomaly (short circuit or overload) must be remedied
- The national standards must be observed for installation and selection of feed and return cables.
- Circuit protection modules 1694-PMD* must be operated with 1694-PFD1244.
- Circuit protection modules 1694-PMD2A10 can be operated with 1694-PFD1244 or 1694-PF* (Line +). Module is recognized automatically.
- IO-Link communication is provided by Power Feed 1694-PFD1244 to Protection Modules. Protection Modules cannot communicate directly with PLC and IO-Link master.
- Standard Protection Modules should not be used in IO-link configuration (for 1694-PMD2A10 see note above).

1.1. 1694-PMD* and 1694-PMD2A10 Circuit Protection Module

Technical data (Tamb = +23 °C, UB = DC 24 V)

Operating voltage U_B	DC 24 V (min. 18 V, max. 30 V) (no battery-buffered applications)	
Closed current I_0 1694-PM1 (1-channel) 1694-PM2 (2-channel)	in ON condition: typically 5 mA typically 8 mA	
Reverse polarity protection	Yes, without load	
Rated current I_N 1694-PM1 (1-channel) 1694-PM2 (2-channel)	current ratings: 1 A, 2 A, 3 A, 4 A, 6 A, 8 A, 10 A 1A/1A, 2A/2A, 3A/3A, 4A/4A, 6A/6A	
Visual status indication by means of LED:	<p>Green: ● Load circuit connected</p> <p>flashing orange ● ● Load current warning limit reached green:</p> <p>orange: ● Overload or short circuit until disconnection</p> <p>red: ● After disconnection (trip condition) due to overload or short circuit after undervoltage release of operating voltage in ON condition with autoreset</p> <p>OFF: ● Device switched off by means of ON/OFF Non Illuminated momentary switch or no operating voltage</p> <p><small>For additional information about LED signaling related communication with PLC by IO-Link technology please refer to chapter: Signalling of operating conditions on 1694-PMD* Protection Module (Page 18).</small></p>	
Load current warning limit (IWLlimit) 1694-PMD2A10 1694-PMD Hysteresis	<p>typically $0.9 \times I_N$ (0.5 ... 1.0 $\times I_N$ configurable)</p> <p>typically $0.9 \times I_N$ (0.5 ... 1.0 $\times I_N$ configurable)</p> <p>typically 5%</p>	
Overload disconnection (I_{OL}) with trip times (t_{OL})	<p>typically $I_{OL}: I_N \times 1.05$ $t_{OL}: 3s$</p> <p>typically $I_{OL}: I_N \times 1.35$ $t_{OL}: 0.5s$</p> <p>typically $I_{OL}: I_N \times 2.00$ $t_{OL}: 0.1s$</p> <p>typically $I_{OL}: I_N \times 2.50$ $t_{OL}: 0.012s$</p>	
short circuit trip time (t_{KS})	typically at (I_{KS}) see time/current characteristics	$t_{KS}: 0.002s^1$
¹ depending on power source		
Influence of ambient temperature on overload trip and load current warning limit	see temperature factor table	
Leakage current in load circuit in OFF condition	typically <1 mA	
Voltage drop in load circuit 1694-PMD between LINE+ and LOAD+	<ul style="list-style-type: none"> • $I_N: 1A$ (CL2) typically 180 mV • $I_N: 2A$ (CL2) typically 110 mV • $I_N: 3A$ typically 120 mV • $I_N: 3A$- CL2 typically 130 mV • $I_N: 4A$ typically 115 mV • $I_N: 4A$- CL2 typically 180 mV • $I_N: 6A$ typically 170 mV • $I_N: 8A$ typically 160 mV • $I_N: 10A$ typically 180 mV 	
Voltage drop in load circuit at I_N for 1694-PMD2A10 between LINE+ and LOAD+	<ul style="list-style-type: none"> • $I_N: 1A$ typically 30 mV • $I_N: 2A$ typically 39 mV • $I_N: 3A$ typically 48 mV • $I_N: 4A$ typically 57 mV • $I_N: 5A$ typically 66 mV • $I_N: 6A$ typically 74 mV • $I_N: 7A$ typically 83 mV • $I_N: 8A$ typically 92 mV • $I_N: 9A$ typically 101 mV • $I_N: 10A$ typically 110 mV 	

4 Installation Instructions: Bulletin 1694 Electronic circuit protection for 24V DC with IO-Link

Fail-safe element integrated fuse	Adjusted to the corresponding rated current I_N
	<ul style="list-style-type: none"> • I_N: 1A (CL2) fail-safe I_N: 1A • I_N: 2A (CL2) fail-safe I_N: 2A • I_N: 3A fail-safe I_N: 3.15A • I_N: 3A-CL2 fail-safe I_N: 4A • I_N: 4A fail-safe I_N: 4A • I_N: 4A-CL2 fail-safe I_N: 4A • I_N: 6A fail-safe I_N: 6.3A • I_N: 8A fail-safe I_N: 8A • I_N: 10A fail-safe I_N: 10A
Low voltage monitoring of operating voltage	OFF at typically $U_B < 16.0\text{ V}$ ON at typically $U_B > 19.0\text{ V}$ Hysteresis typically 2 V with automatic OFF and ON operation
ON delay - with power ON	channel 1: typically 100 ms (1694-PMD) channel 2: typically 200 ms (1694-PMD) channel 1: typically 1,500 ms (1694-PMD2A10, depending on slot) channel 2: typically 1,600 ms (1694-PMD2A10, depending on slot)
- when switching on via ON/OFF momentary switch	channel 1: typically 5 ms channel 2: typically 100 ms
- after an undervoltage	channel 1: typically 5 ms channel 2: typically 5 ms
Disconnection of the load circuit	<ul style="list-style-type: none"> - manually on the device with the ON/OFF momentary switch - after an overload / short circuit disconnection with storage (no automatic reset) - temporarily at undervoltage - at no operating voltage - remote control via the PLC and IO-Link master control unit
Switching on the load circuit	
- Momentary switch ON/OFF	Unit can only be switched ON when operating voltage was applied The circuit protector can be switched ON by the PLC and IO-Link master or otherwise directly on the device. These two options are linked with AND. Switch ON is only possible if switched ON from both positions. If the circuit protector was switched OFF either by the control unit or by the momentary switch directly on the device, switch ON must be affected also from the corresponding position.
- Apply operating voltage	The device re-starts with the last stored condition.
Read currently adjusted rated current of 1694-PMD2A10	Reading the currently adjusted current rating is, independent of the operating mode (COM or standard), possible for each channel directly on the 1694-PMD2A10. Enquiry mode is started by pushing the button between ≥ 2 seconds and < 5 seconds After releasing the button, the LED is RED for 333 ms to indicate start of enquiry. Afterwards, the LED flashes ORANGE in a puls/break ratio of 1/2 with a frequency of 1 Hz to indicate the adjusted current value. When the adjusted current rating is reached, signaling re-starts after the RED LED re-lights for 333 ms. The enquiry mode is left after the adjusted current rating was signaled 5 times or by pressing the button. Visual indication will now show again the current operating condition. The enquiry mode is possible in all operating conditions (ON, OFF, UNDERVOLTAGE and TRIPPED).
Setting the current ratings of 1694-PMD2A10	The adjustment mode directly on the 1694-PMD2A10 can only be activated in standard mode. The adjustment mode is started per channel by pushing the button for ≥ 5 seconds. After releasing the button, the LED is RED for 333 ms to indicate start of adjustment. The LED is blinking GREEN with a pulse/break ratio of 1/4 at a frequency of 0.6 Hz for visual indication. GREEN After reaching the max. adjustment value, signaling re-starts. Overrun of the max. adjustment value after 1 Ampere is indicated by the RED LED (333 ms). The current rating to be adjusted is adopted by pushing the button during the blinking period of 1 A up to the max. adjustment value. If for instance the button is pushed after the 7th illumination of the GREEN LED, 7A is adopted as current rating and visual indication again shows the current operating condition. If the button is not pressed, the adjustment mode is left after 5 times signaling the current rating range without a new current rating being adopted and the visual indication returns to current status indication. The adjustment mode is possible in all operating conditions (ON, OFF, UNDERVOLTAGE and TRIPPED).
Reset function for 1694-PMD* and 1694-PMD2A10	A blocked load output (blocked by overload / short circuit) can be reset or switched on manually by the momentary ON/OFF switch (LED button).
Capacitive loads (Depending on: cable attenuation, power supply used, load current and current rating)	at I_N : 1A DC24V up to 5,000 μ F at I_N : 2A, 3A DC24V up to 10,000 μ F at I_N : 4A DC24V up to 12,000 μ F at I_N : $> 6A$ DC24V up to 20,000 μ F
Free-wheeling circuit	external free-wheeling circuit at inductive load (rating according to load) is recommended.
Parallel connection of several load outputs	not permitted

5 Installation Instructions: Bulletin 1694 Electronic circuit protection for 24V DC with IO-Link

General data 1694-PMD*

Housing material	plastic
Mounting method	symmetrical rail to EN 60715-35x7.5
Ambient temperature (T _{amb})	-25°...+60 °C (without condensation, cf. EN 60204-1)
Storage temperature	-30°...+70 °C
Mounting temperature	+5°... +60°C
Humidity:	96 hrs / 95% RH RH/40 °C to IEC 60068-2-78-Cab climate class 3K3 to EN 60721
Vibration resistance	3 g, test to IEC 60068-2-6 test Fc
Degree of protection	IEC 60529, DIN VDE 0470
Operating area 1694-PMD*	IP30
EMC requirements (EMC Directive, CE Logo)	Emitted interference: EN 61000-6-3 Noise immunity: EN 61000-6-2
Insulation co-ordination (IEC 60934)	0.5 kV / pollution degree 2
Dielectric strength	max. DC 30 V (load circuit)
Insulation resistance (OFF condition)	n/a, only electronic disconnection
Modules mountable side by side	max. 16 channels
Terminals Push-in terminal PT 2.5	0.14mm ² to 2.5mm ² , flexible AWG24 – AWG14 str.
wire stripping length	8mm to 10mm
Rockwell Automation recommends to use ferrules for smaller diameter cables.	
Dimensions (h x w x d)	12.5 x 80 x 98.5 mm
Weight	approx. 60 g

Conformity and approvals for 1694-PMD* with 1694-PFD1244

Conformity	CE Marking RoHS compliant China RoHS WEEE Morocco EMC
Approvals	UL 2367 RA File # E350272 current rating range:1A... 10A UL 1310 current rating range: NEC Class2 ³ 1A, 2A, 3A, 4A cULus508RA RA File # E56639 current rating range:1A... 10A listed

³ Class 2 only for Protection Modules



At the End of its life, this equipment should be collected separately from any unsorted municipal waste.

Typical time/current characteristic ($T_{amb} = +23\text{ °C}$, UB = DC 24 V)

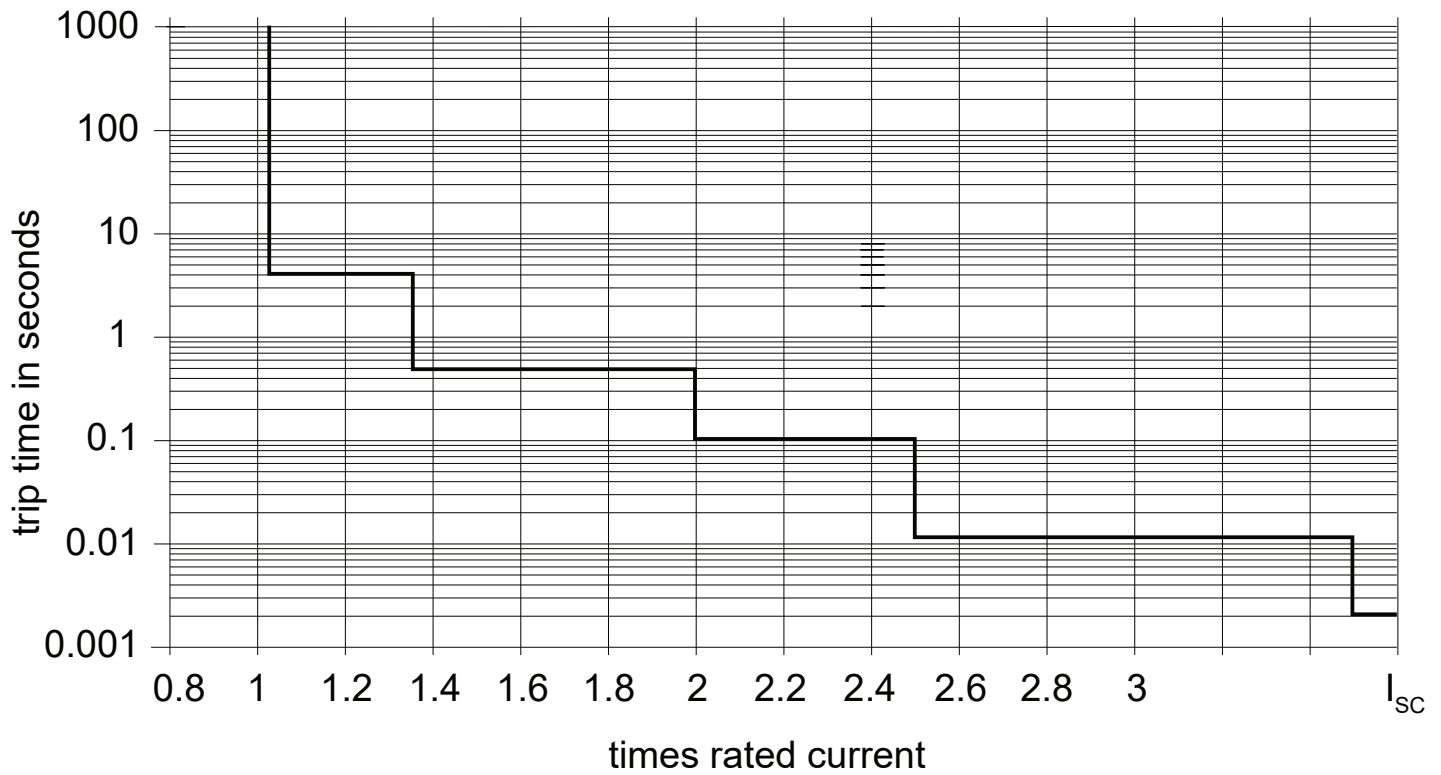

I_{sc} - short circuit current

Temperature factor / continuous duty

The time/current characteristic depends on the ambient temperature. In order to determine the max. load current, please multiply the current rating with the temperature factor and consider the factor for side-by-side mounting.

Temperature factor table:

ambient temperature [°C]	0	10	23	40	50	60
temperature factor	1	1	1	0.95	0.90	0.85

Please note

- When mounted side-by-side, the devices can carry max. 80 % of their rated load or a different rating has to be selected.
- With high temperatures, the load current warning threshold “warn limit typically $0.9 \times I_N$ ” will be reduced in accordance with the temperature factor.
- Selection of current rating of the circuit protector \leq rating of power supply.

Dimensions 1694-PMD*

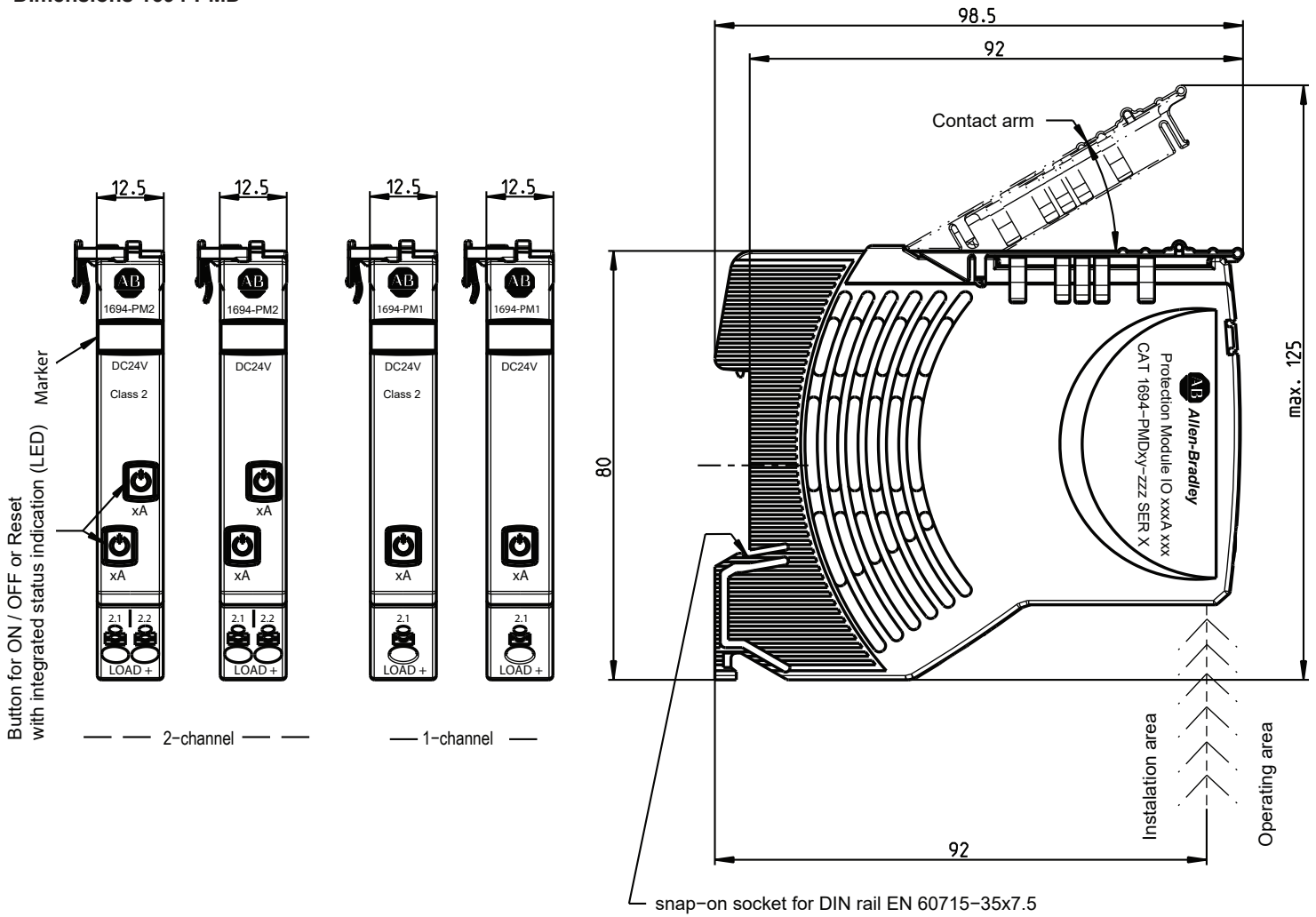

Small opening above the screwdriver insert (marked as 2.1 and 2.2) = voltage measuring point.
 Larger opening under the screwdriver insert (marked as LOAD +) = wire connection area.

General recommendation for all 1694 modules installation.

For installation instructions please refer to item: Mounting on or removing of 1694-* from symmetrical rail (Page 11)

Product selection list - 1694-PMD*

Catalog Code	Description
1694-PMD110	Electronic Circuit Protection, Protection Module, IO-Link, 1-Channel, Fix Current, 10A
1694-PMD18	Electronic Circuit Protection, Protection Module, IO-Link, 1-Channel, Fix Current, 8A
1694-PMD211	Electronic Circuit Protection, Protection Module, IO-Link, 2-Channels, Fix Current, 1A, 1A
1694-PMD211-CL2	Electronic Circuit Protection, Protection Module, IO-Link, 2-Channels, Fix Current, 1A, 1A, Class 2
1694-PMD222	Electronic Circuit Protection, Protection Module, IO-Link, 2-Channels, Fix Current, 2A, 2A
1694-PMD222-CL2	Electronic Circuit Protection, Protection Module, IO-Link, 2-Channels, Fix Current, 2A, 2A, Class 2
1694-PMD233	Electronic Circuit Protection, Protection Module, IO-Link, 2-Channels, Fix Current, 3A, 3A
1694-PMD233-CL2	Electronic Circuit Protection, Protection Module, IO-Link, 2-Channels, Fix Current, 3A, 3A, Class 2
1694-PMD244	Electronic Circuit Protection, Protection Module, IO-Link, 2-Channels, Fix Current, 4A, 4A
1694-PMD244-CL2	Electronic Circuit Protection, Protection Module, IO-Link, 2-Channels, Fix Current, 4A, 4A, Class 2
1694-PMD266	Electronic Circuit Protection, Protection Module, IO-Link, 2-Channels, Fix Current, 6A, 6A
1694-PMD2A10	Electronic Circuit Protection, Protection Module, IO-Link, 2-Channels, Adjustable Current, 1A to 10A

2. Bulletin 1694. Power Feed 1694-PFD1244 with IO-link communication

The 1694-PFD1244 Power Feed module receives the DC 24 V supply voltage, e.g. from a switched mode power supply, and distributes it to the mounted circuit protectors via the integral connector arm of the 1694-PMD. Build-in LED provides information about setup status. Built-in IO-Link communication offers control and monitoring by PLC of each attached electronic circuit protection module 1694-PMD1244. One IO-Link Power Feed can control max 16 channels.

- Main Communication features:
 - Current monitoring for each attached channel
 - Voltage monitoring for each attached channel
 - Input voltage monitoring
 - Statistics for each attached output channel
 - Max, min, average current value
 - Max, min, average voltage value
- Remote control,
 - Remote switch ON and switch OFF
 - Remote trip reset
 - Channel monitoring parameters change (warning limits)
 - Trip current limit change for adjustable module (1694-PMD2A10)
- Error messaging.
 - Protection module errors messaging
 - Power feed errors messaging
- Last trip information for each channel.
 - Trip counter
 - Last trip reason
 - Trip current

Provided features significantly help for quick troubleshooting.
 User need to use IO-Link master in the setup to build communication capable configuration

Sample schematic data connection of IO-Link bulletin 1694 devices to ethernet network and PLC

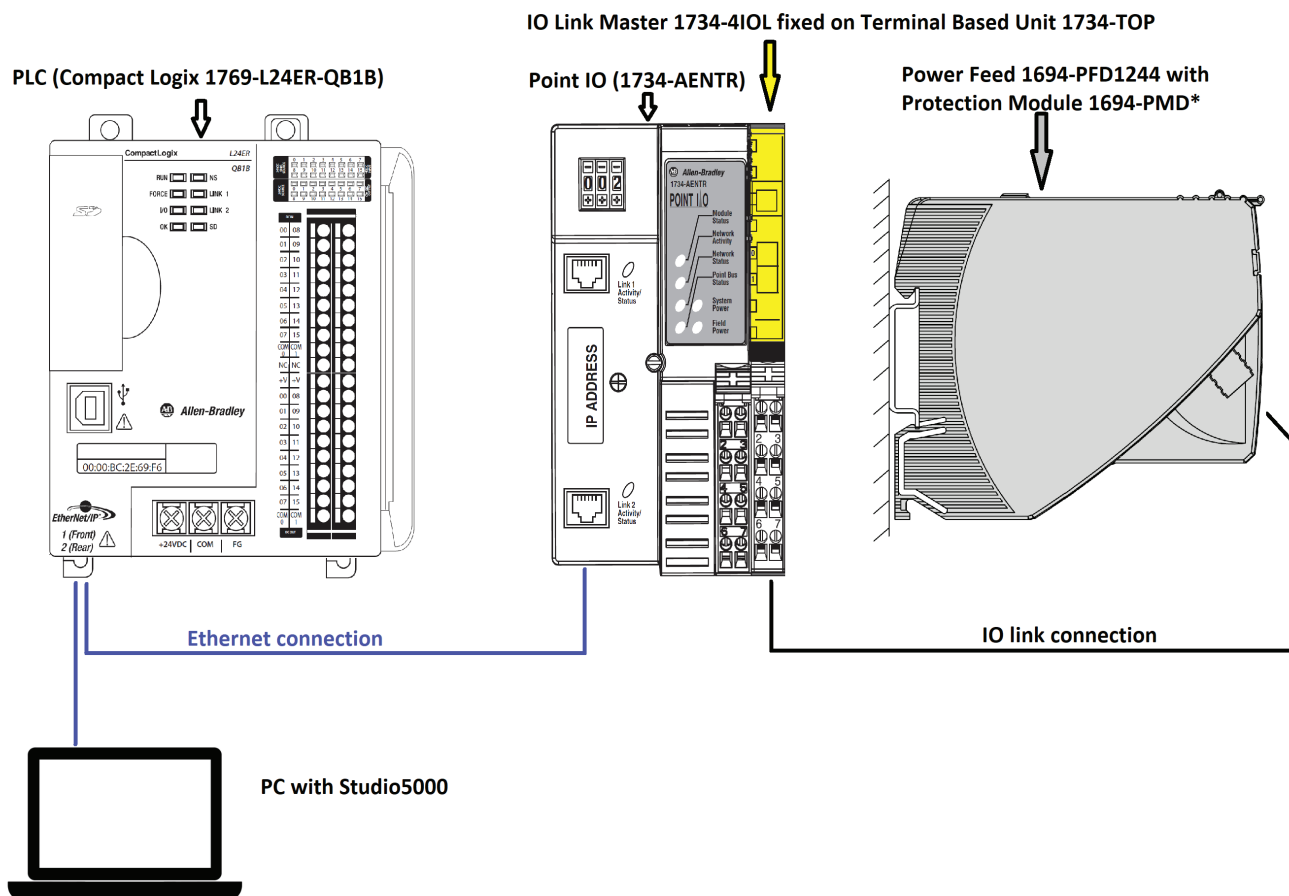

2.1. 1694-PFD1244 Power Feed Module

Technical data (T_{amb} = +23 °C, UB = DC 24 V)

Operating voltage UB	DC 24 V (min. 18 V, max. 30 V) (no battery-buffered applications)
Operating current IB	Max. 40 A
Reverse polarity protection	Yes, without load
Closed current I0	normal condition: typically 20 mA
Circuit protectors can be mounted side-by-side 1694-PMD1* 1-channel or 1694-PMD2* 2-channels or 1694-PMD2A10 2-channels	max. 16 pieces
Visual status indication by means of LED:	<p>Green: ● Faultless operations</p> <p>Blinking green: ● Independent operations</p> <p>Red: ● Critical Anomaly</p> <p>Orange ● Uncritical Anomaly (communication available)</p> <p>Blinking Orange ● Uncritical Anomaly (communication not available)</p> <p>OFF: ● Device switched off.</p> <p>For additional information about LED signaling related to IO-Link communication please refer to chapter: Signaling of operating conditions on 1694-PFD1244 Power Feed Module (Page 17).</p>
IO-Link Connection	3 pins communication interface to IO-Link master. For more information please refer to chapter: IO-Link connector description (Page 16).

General data 1694-PFD1244

Housing material	plastic
Mounting method	symmetrical rail to EN 60715-35x7.5
Ambient temperature (T _{amb})	-25°...+60 °C (without condensation, cf. EN 60204-1)
Storage temperature	-30°...+70 °C
Mounting temperature	+5°... +60°C
Corrosion	96hrs. in 5% salt mist to IEC 60068-2-11 test Ka
Humidity:	96 hrs / 95% RH RH/40 °C to IEC 60068-2-78-Cab climate class 3K3 to EN 60721
Vibration resistance	3 g, test to IEC 60068-2-6 test Fc
Degree of protection terminal	IEC 60529, DIN VDE 0470 IP20
EMC requirements (EMC Directive, CE Logo)	Emitted interference: EN 61000-6-3 Noise immunity: EN 61000-6-2
Insulation co-ordination (IEC 60934)	0.5 kV / pollution degree 2
Dielectric strength	max. DC 30 V (load circuit)

10 Installation Instructions: Bulletin 1694 Electronic circuit protection for 24V DC with IO-Link

Insulation resistance (OFF condition) n/a, only electronic disconnection

Terminals	LINE+
Push-in terminal PT 10	0.5mm ² to 10mm ² , flexible
wire stripping length	AWG20 – AWG8 stranded 18mm
Terminals	0V
Push-in terminal PT 2.5 (0V)	0.14mm ² to 2.5mm ² , flexible
wire stripping length	AWG24 – AWG14 stranded 8mm to 10mm
Dimensions (h x w x d)	12.5 x 80 x 98.5 mm
Weight	approx. 56 g

Conformity and approvals for 1694-PFD1244 with 1694-PMD*

Conformity	CE Marking China RoHS WEEE Morocco EMC
Approvals	UL 2367 RA File # E350272 current rating range: 1A... 10A
	cULus508 listed RA File # E56639 current rating range: 1A... 10A



At the End of its life, this equipment should be collected separately from any unsorted municipal waste.

Dimensions 1694-PFD1244

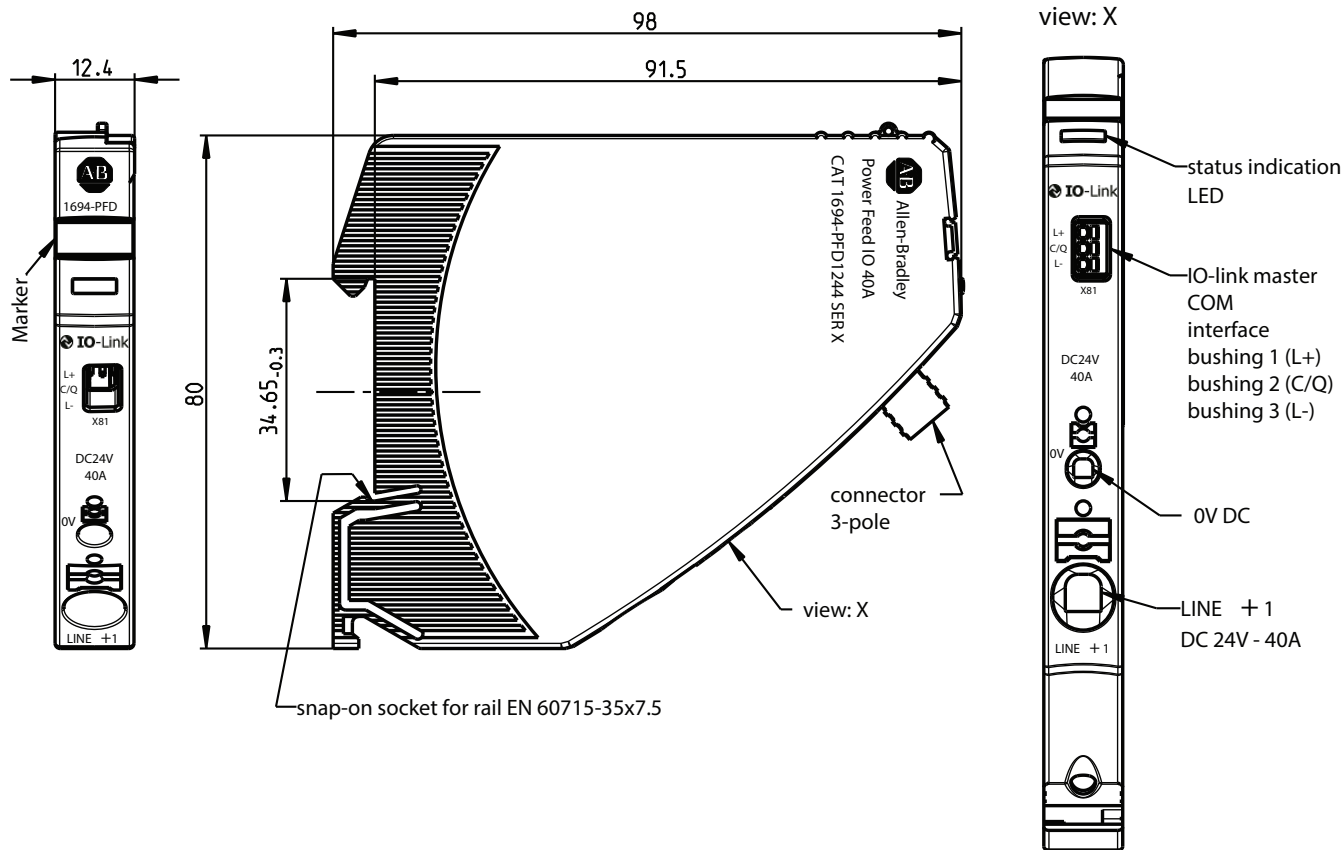

Configuration example

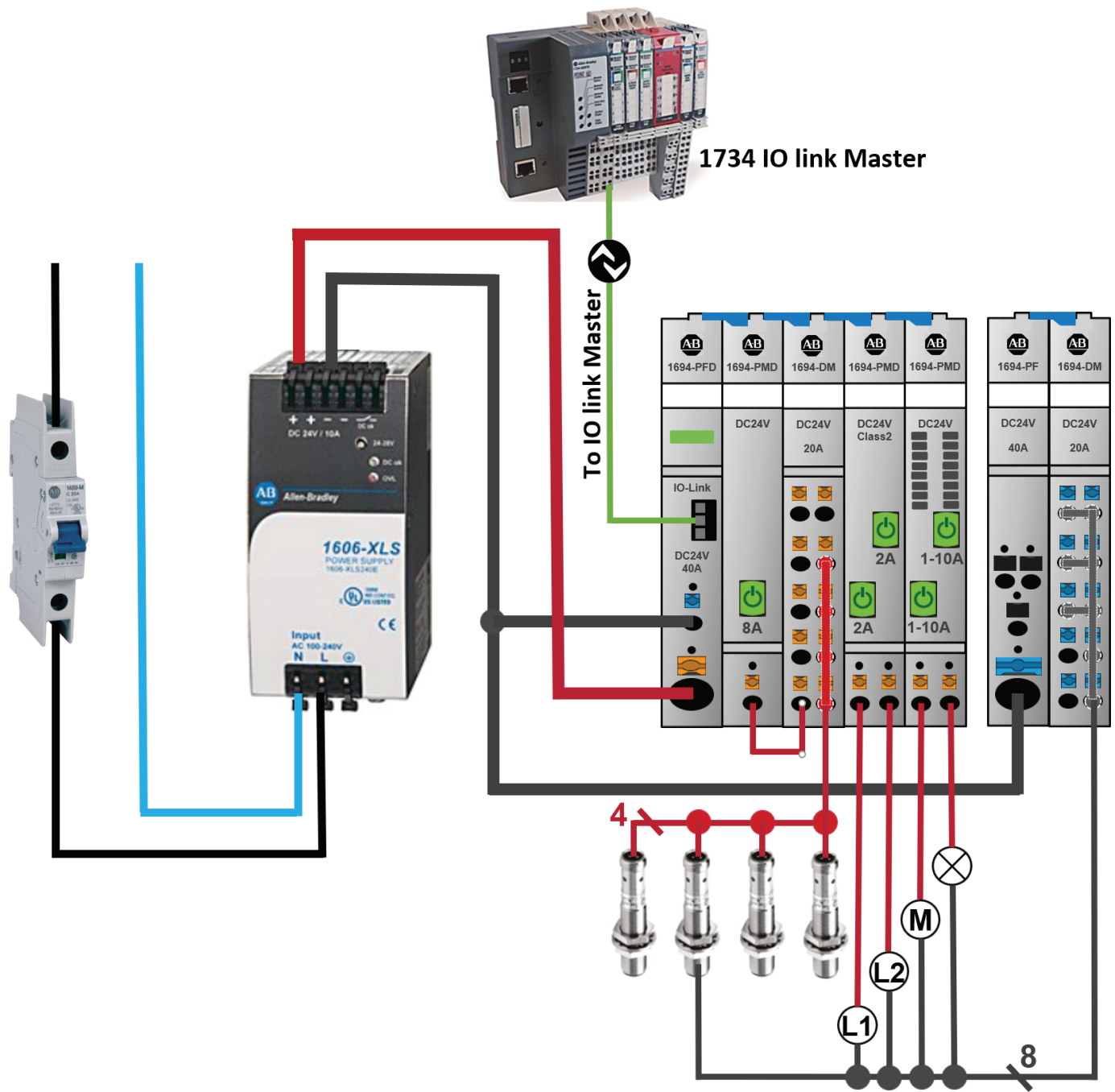

Module configuration in sample schematic diagram

Starting from left position:

- 1694-PFD1244
- 1694-PMD18
- 1694-DM1L2
- 1694-PMD222-CL2
- 1694-PMD2A10
- 1694-PF1G4
- 1694-DM3G2

Mounting on or removing of 1694-* from symmetrical rail

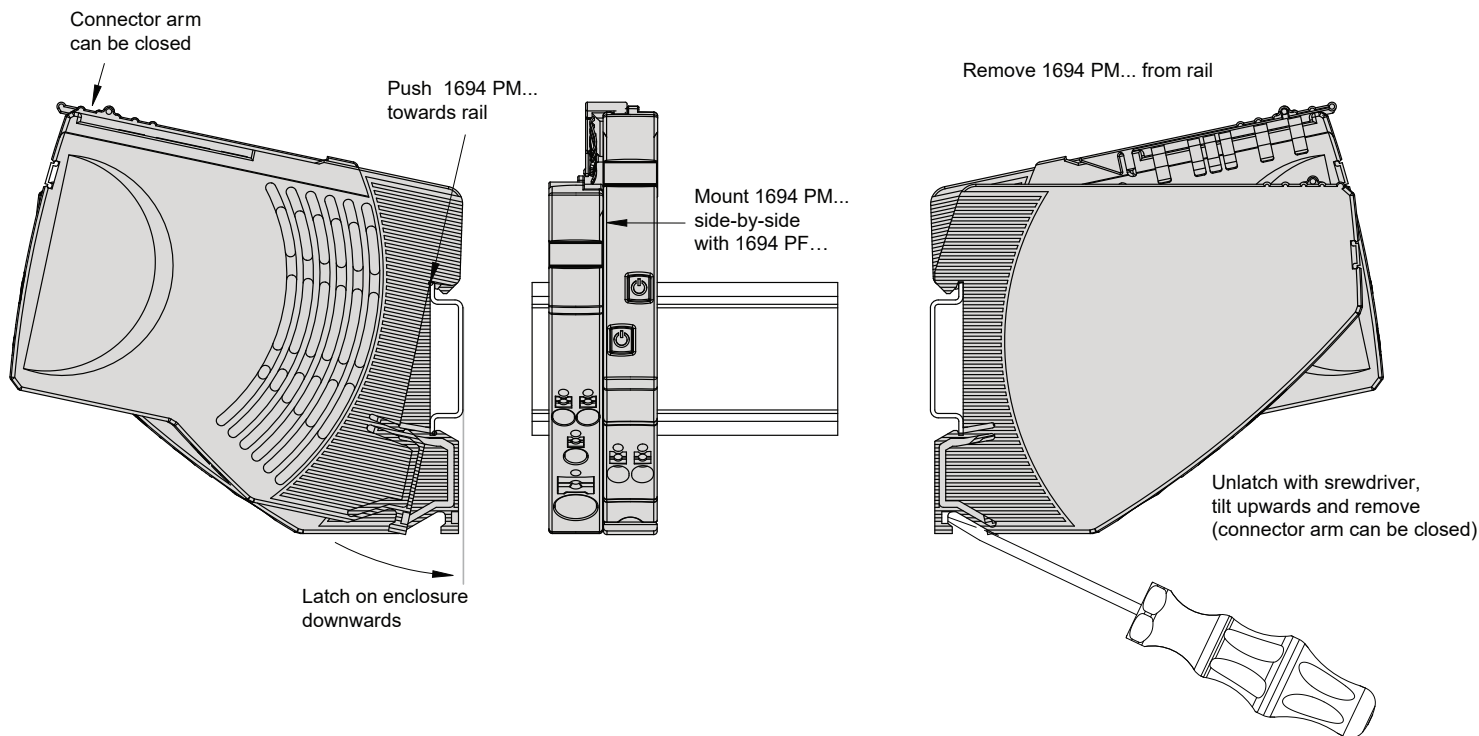

Please note

- Sliding on DIN rail is not permitted.
- Open connector arm carefully to avoid damage

General recommendation for all 1694 modules installation.

Screwdriver for installation:

- blade-style screwdriver size 1 for smaller Push-in terminal (PT 2.5) inserts
- blade-style screwdriver size 4 for larger Push-in terminal (PT 10) inserts

Mounting position:

- horizontal mounting position is preferred



Hot swap of circuit protectors is not permitted

- Opening under load can damage the device or cause undefined system conditions.

The electronic circuit protection module can at any time be mounted side by side with a supply module or an existing system.

Opening the connector arm is only permitted in the OFF (No input voltage) condition. After plugging in a circuit protector, it will automatically be identified and parameterized if parameters are available for the slot. During this procedure, the cyclical data will be marked as invalid for a short period of time.

Removing 1694-* devices from DIN rail

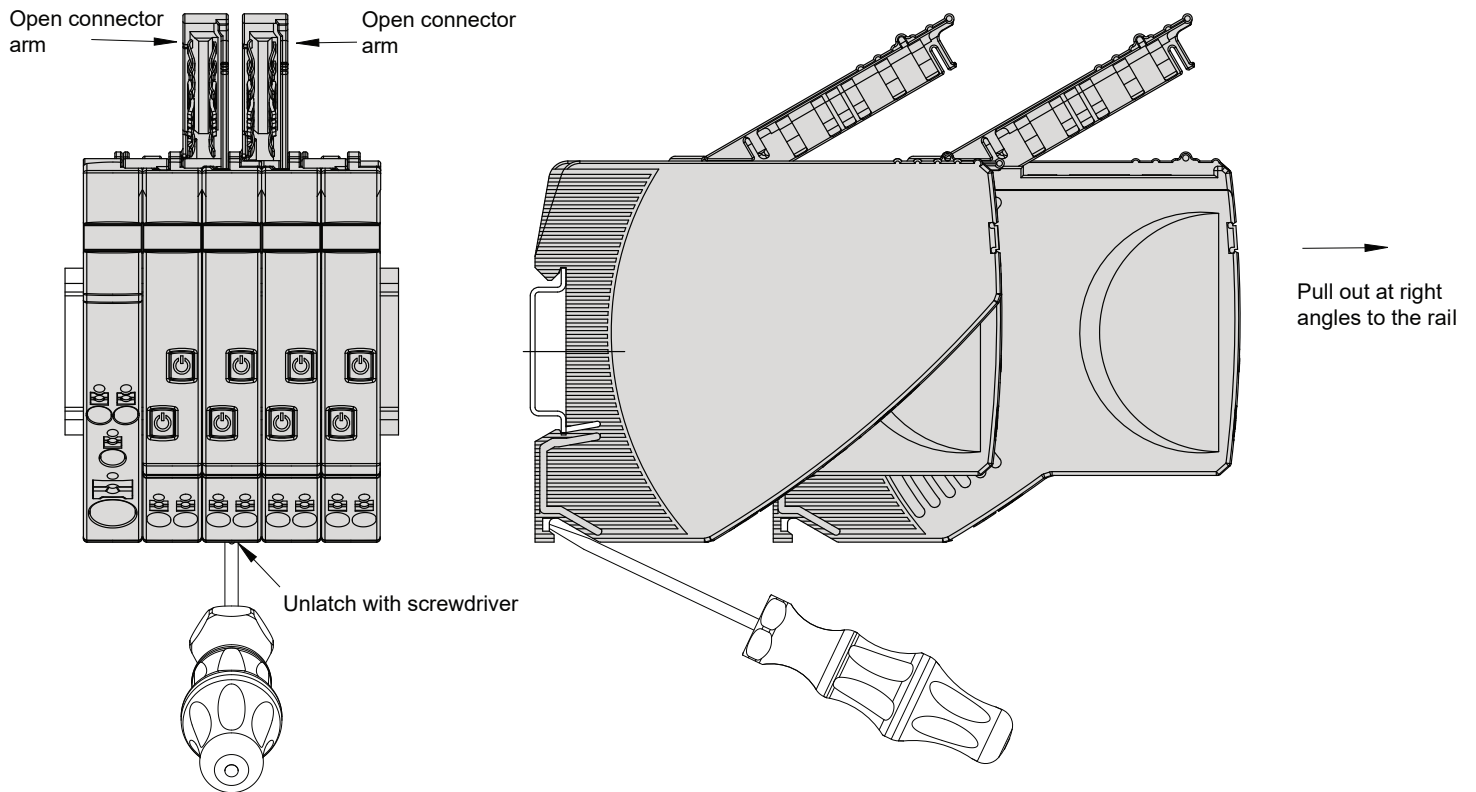

Caution: Exchange/disassembly only in dead-voltage condition! Potentials will be interrupted.

Locked connector arms of 1694-PM...

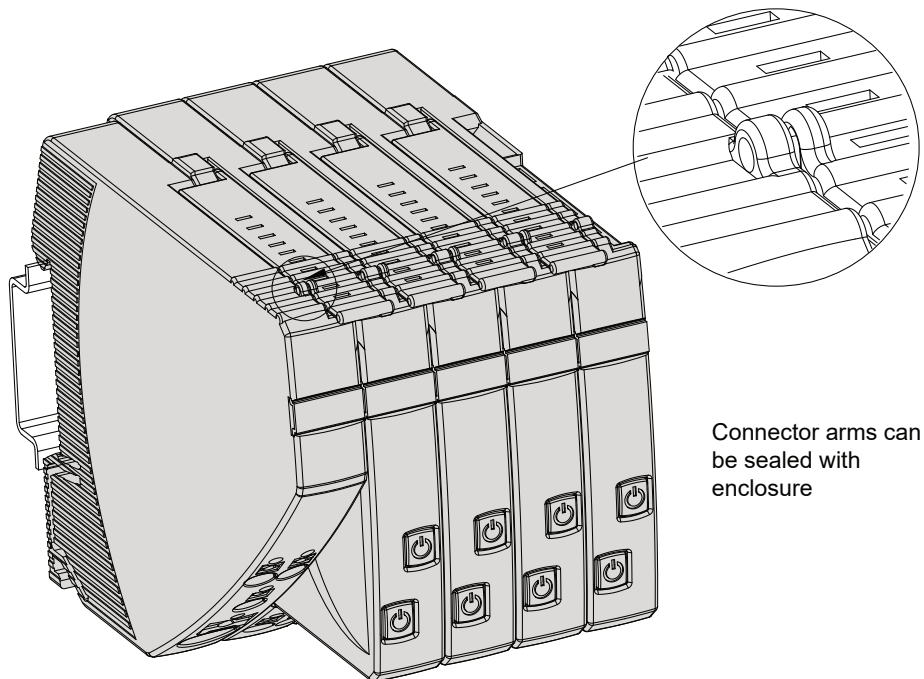

Distance between cable duct and connector arm of 1694-*

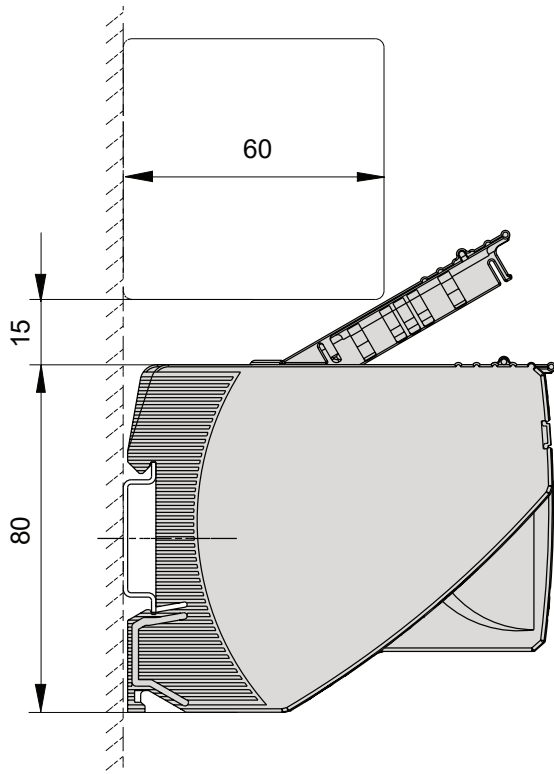

Installation area – operating area for 1694-*

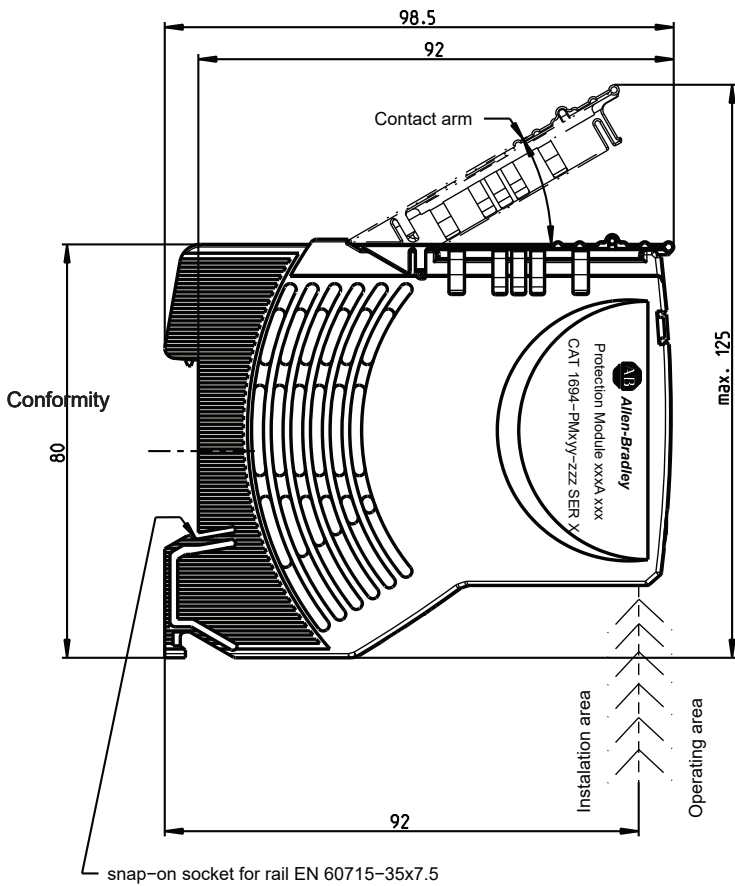

3. IO-Link technology review

Please note: This is a very short overview of IO-Link technology. For more details please refer to IO-Link specification published on IO-Link community webpage <https://io-link.com>.

What is IO-Link technology?

The IO-Link technology is an open point-to-point communication standard and was launched as (IS) IEC 61131-9. IO-Link is now the globally standardized technology developed initially mainly for sensor and actuator communication with a field bus system. This technology provides benefits to both OEMs and End Users.

IO-Link provides communications-capable devices to the control level by a cost-effective point-to-point connection. IO-Link provides a point-to-point link between the I/O module and device that is used for transferring detailed diagnostics, device identity information, process data, and parameterization.

IO-Link communication is based on a structure in which the master controls the interface access to the IO-Link device. The option of using the intelligence that is integrated into the IO-Link device provides the user with new commissioning methods. Benefits range from reduced installation time during startup to increased diagnostics over the lifetime of the machine. Benefits of IO-Link technology include:

- Reduced inventory and operating costs
- Increased uptime/productivity
- Simplified design, installation, set up and maintenance
- Enhanced flexibility and scalability
- Detailed diagnostic information for preventative maintenance

Why IO-Link?

IO-Link Offers a Full Range of Advanced Features and Functions

Seamless Integration

- Forward and backward compatible,
- No special cables required
- Connectivity options remain the same
- Access IO-Link functionality by simply connecting an IO-Link enabled device to an IO-Link master

Real-time Diagnostics and Trending

- Real-time monitoring of the entire machine down to the IO-Link device level
- Optimized preventative maintenance—identify and correct issues before Anomaly can occur
- Detect IO-Link device malfunctions/Anomalies

IO-Link Device Health Status

- Real-time monitoring helps ensure that IO-Link devices are operating correctly
- Detect damaged IO-Link device and pinpoint their exact location for quick troubleshooting through Application Specific Name parameter

Device Profiles and Automatic Device Configuration

- IO-Link technology provide user with quick IO-Link device configuration within minutes instead of hours,

Descriptive tags

- Faster programming during initial setup
- More efficient troubleshooting process—data tags are named based on the information they provide
- Easily monitor device data through intuitive tag names

How IO-Link works?

IO-Link delivers data over the same standard field cabling used today. By connecting an IO-Link device to an IO-Link master, the field-device data and diagnostics are accessible. So go beyond detecting products on the machine—now the health of the machine can be MONITORED as it runs.

IO-Link Data Types

There are four data types available through IO-Link:

Process Data (cyclic data)

The process data of the devices are transmitted cyclically in a data frame in which the size of the process data is specified by the device. Depending on the device, 0...32 bytes of process data are possible (for each input and output). The consistency width of the transmission is not fixed and is thus dependent on the master.

Value Status (cyclic data)

The value status indicates whether the process data is valid or invalid. The value status can be transmitted cyclically with the process data.

Device Data (acyclic data)

Device data supports device-specific configurable parameters, identification data, and diagnostic information. They are exchanged acyclically and at the request of the IO-Link master. Device data can be written to the device (Write) and read from the device (Read)

Events (acyclic data)

When an event occurs, the device signals the presence of the event to the master. The master then reads out the event. Events can be error messages and warnings/maintenance data. Error messages are transmitted from the device

3.1. Accessing IO-Link Data

Cyclic Data

To exchange the cyclic process data between an IO-Link device and a controller, the IO-Link data from the IO-Link master is placed on the address ranges assigned beforehand. The user program on the controller accesses the process values using these addresses and processes them. The cyclic data exchange from the controller to the IO-Link device is performed in reverse.

Acyclic data (Non-cyclic data)

Acyclic data, such as device parameters or events, are exchanged using a specified index range. The controller accesses these using Explicit Messaging. The use of the index ranges allows targeted access.

4. IO-Link connector description used for 1694-PFD1244

IO-Link connector

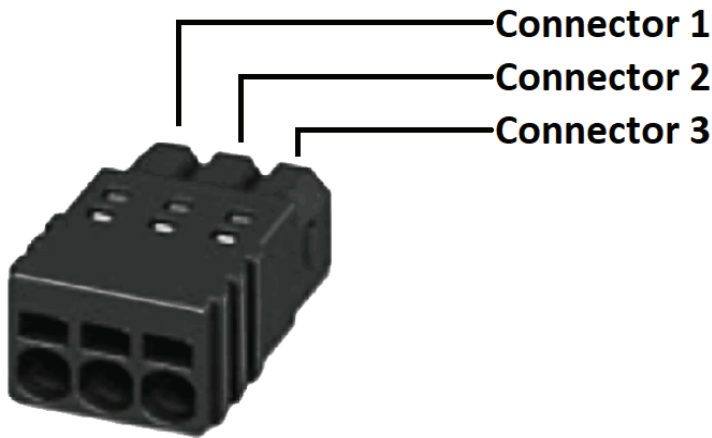

Connection to IO-Link bus system.
This plug is delivered with Power Feed device.
Push-in terminals

Recommended cable parameters:
Cable length: max 20m
Cross section: 0.25 mm² to 0.5 mm²
stripping length = 6 mm

The cable does not have to be shielded specially.

Connector 1: IO-Link Terminal + (24V DC)

Connector 2: IO-Link Terminal C/Q (Data Cable to IO-Link master)

Connector 3: IO-Link Terminal L- (GROUND)

Connector 1 and 3 provide the energy for IO-Link control circuit in Power Feed

For wire connection please use 0 size flat-head screwdriver. By inserting the screwdriver into the rectangular openings of the connector plug, the terminals are opening (for wire insert).

5. Signaling of operating status on 1694-PFD1244 Power Feed Module

LED button can signal following channel operational status:

Operational status	LED button signal	IO-Link communication
System start	Orange (for approx. 1 sec)	Not available
Normal operations	Green	Available
Independent operations	Blinking green	Not available
Critical anomaly detected	Red	Not available
Non-critical anomaly detected	Orange	Available
Non-critical anomaly detected	Blinking orange	Not available

Operating status: System start

When applying the supply voltage, the Power Feed will be initialized. The device will carry out implemented program memory tests and self-test routines. During this time, a communication via the interfaces is not possible. When system is starting, this operational status is indicated by orange color of LED for approximately 1 second.

Operational status: Normal operations.

If there is no fault and a connection to IO-Link master is established, the Power Feed will be into the operating mode "faultless operation". The parameters will be transmitted from the IO-Link master to the Power Feed and be saved there. Subsequently they will be forwarded to the electronic circuit protectors. The configuration data and the parameters will be exchanged as non-cyclical data between the IO-Link master and the Power Feed.

Operational status: Independent operations

If no connection to the IO-Link master is recognized after the supply voltage was applied, the module will change into the operating mode "independent operations".

The parameters stored in the Power Feed will be transmitted to the Protection Modules.

This operational mode will appear always when communication to IO-Link master is interrupted.

This operation mode will disappear always when communication to IO-Link master is restored.

If there is a connection between the Power Feed and IO-Link master and there is no critical anomaly, the Operational status: "independent operations" will be quitted.

The behavior of the Power Feed and Protection Modules can be defined in the event of a communication interruption to IO-Link master. User can choose if Protection Modules should work continuously or be switched OFF in case of communication lost.

Operational status: Critical anomaly.

If an anomaly is detected during the self-test routines, the Power Feed will change into status: "Critical anomaly". In the event of a critical anomaly this operating mode can only be discontinued re-starting the device and it prevents the data exchange via the interfaces. If the Power Feed is in Critical anomaly status, then no communication is possible with control unit. The Protection Modules cannot be controlled by it and remain OFF.

Operational status: Non-critical anomaly.

If there are invalid data or configuration data are not available, the Power Feed will go into Non-Critical anomaly mode. This mode allows only restricted non-cyclical data exchange. Cyclical data exchange is prevented. Non-critical anomaly mode will be left when user setup the correct module, slot parameters and configuration. The protection modules remain OFF.

6. Signaling of operating status on 1694-PMD* Protection Modules

LED button can signal following channel operational status:

Operational status	LED button signal	Condition of load output
Device switched off by means of ON/OFF momentary switch or no operating voltage.	Dark	OFF
Channel ON by momentary switch and OFF by IO-Link in PLC Control mode .	Orange	OFF
Channel ON by momentary switch and IO-Link in PLC Control mode .	Green	ON
Load current warning limit reached.	Blinking green/orange	ON
Channel Overload detected.	Orange	ON
Trip by short circuit or overload.	Red	OFF
Low input voltage detected.	Red	OFF

Pay attention on specific signaling in PLC Control mode.

7. Installation and configuration of 1694-PFD1244 and 1694-PMD* in Studio5000

7.1. AOP Installation

Add-on Profiles are files that users add to their Rockwell Automation® library. These files contain the pertinent information for configuring a device that is added to the Rockwell Automation network. The Add-on Profile simplifies the setup of devices because it presents the necessary fields in an organized fashion. The Add-on Profile allows for set up and configuration of systems in a quick and efficient manner. The Add-on Profile is a folder that contains numerous files for the device. It comes as an installation package.

Before start making a project in Studio5000 it is recommended to verify if proper and newest versions of AOP files are installed. In this example you will need AOP for Point IO 1734-AENTR and IO-Link Master 1734-4IOL.

If the AOP is required to be downloaded and installed, then please use following link:

<https://download.rockwellautomation.com/esd/download.aspx?downloadid=addonprofiles> (registration required)

Extract the AOP zip file, open the folder, and execute the “MPSetup” application file.

7.2. Creating a Project

Following steps shows how to create simple configuration with 1694-PFD1244 and 1694-PMD* modules.

To begin a new project in Studio 5000, follow these steps.

1. Double Click the icon of Studio5000. In this example version 32 of Studio5000 is used.



2. Click New Project



7.3. Adding a Controller

3. To program the controller, select the controller that is used. In this example, it is used the “1769-L24ER-QB1B” CompactLogix.

4. After selecting the controller, name the project and click “Next” in the example, the project name is “ECP”.

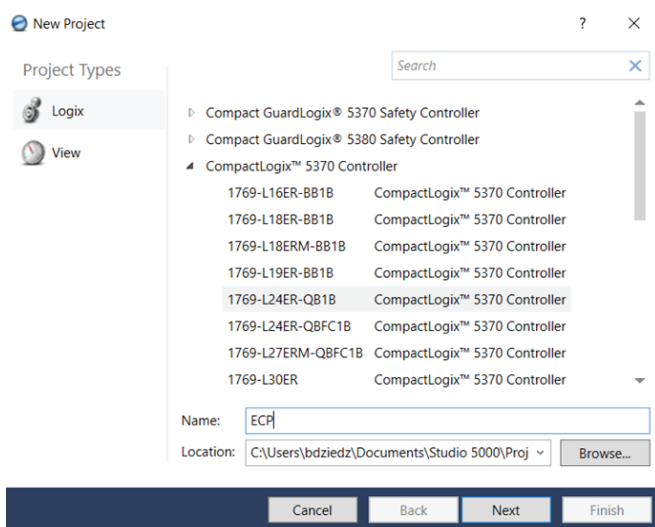

Depending on Studio5000 version you might be requested to set up some additional parameters as shown on below picture. Chose what you need and press “Finish”.

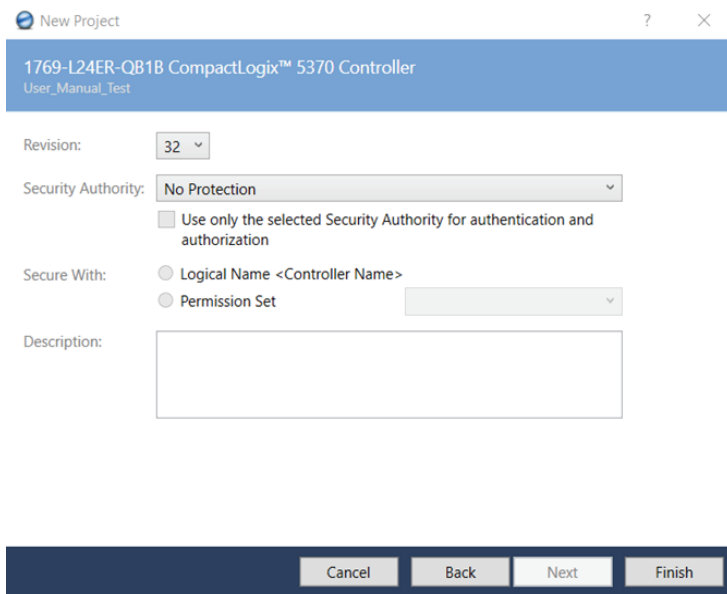

7.4. Adding a Point IO (Ethernet Adapter)

5. Add Point IO to the project. In this project 1734-AENTR point IO is used. To add device to the project, Studio500 must be in “Offline” mode as shown in the picture below

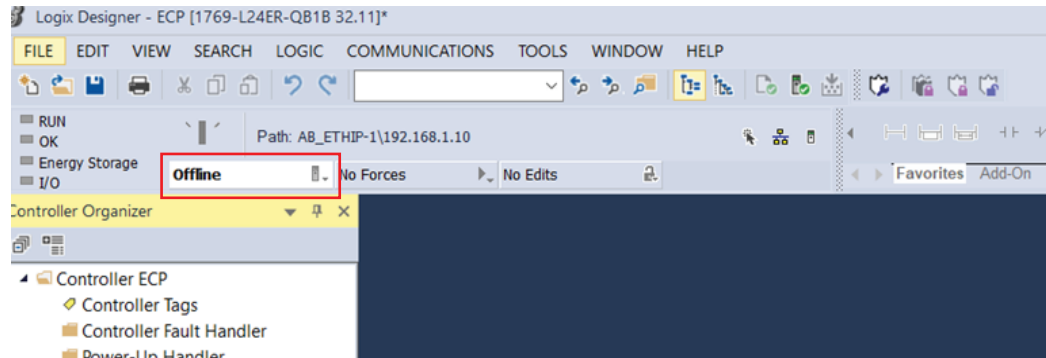

6. In the controller organizer tree, find Ethernet under I/O Configuration and right-click to “add new module”.

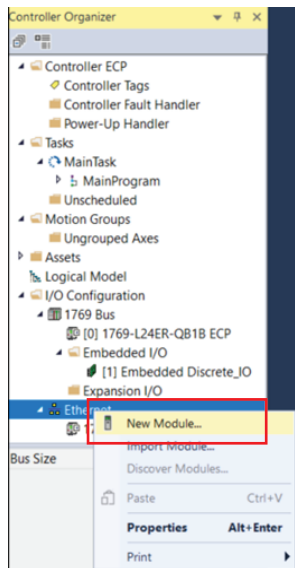

7. The module window pops up and shows the available modules. Use the filter to select “1734-AENTR” Point IO module and click “Create” button.

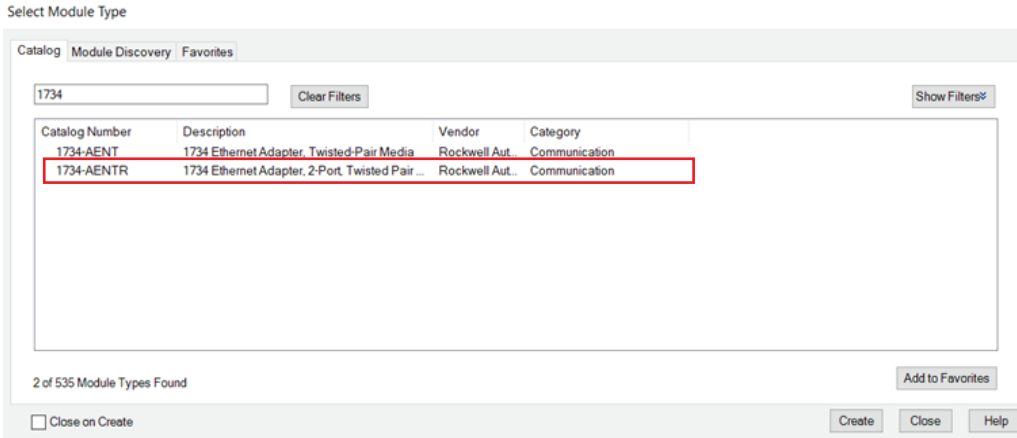

8. Name the Ethernet adapter (in this example we used name “Point IO”), set the chassis size, check the module revision, and set up the adapter IP address. Click OK and Close.

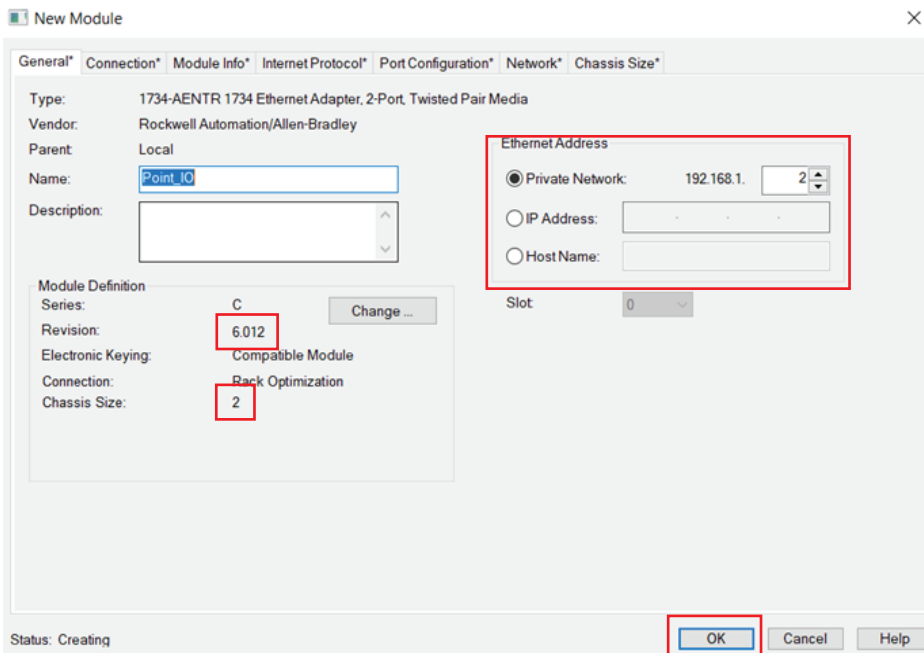

9. The 1734 AENTR module is now visible in the Controller Organizer tree in the Ethernet section.

7.5. Adding an IO-Link Master

10. Now IO-Link Master module must be added. Make sure that the controller is offline prior you start configuration. In the Controller Organizer tree, find Ethernet under I/O Configuration and right-click to “add new module” on Ethernet adapter 1734-AENTR.

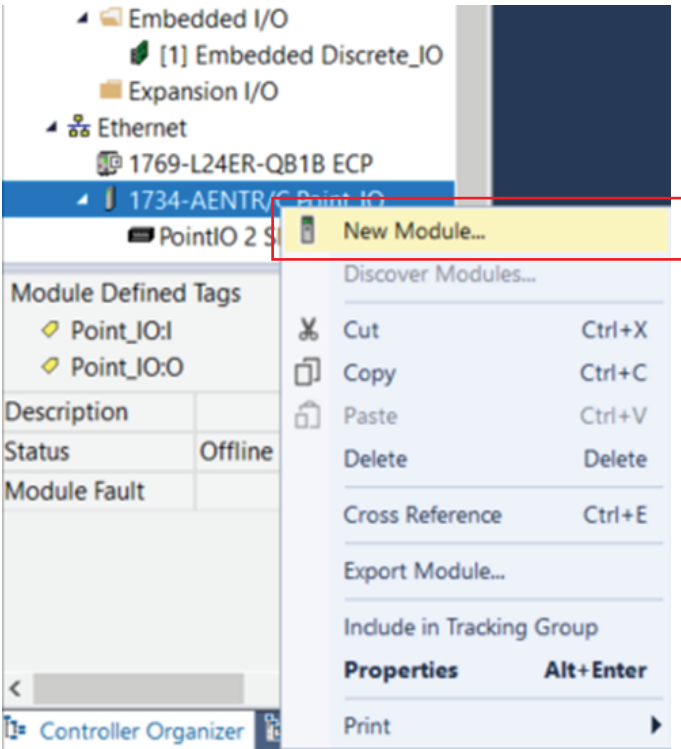

11. The module window pops up and shows the available modules. Use the filter to select “1734-4IOL” module and click “Create” button.

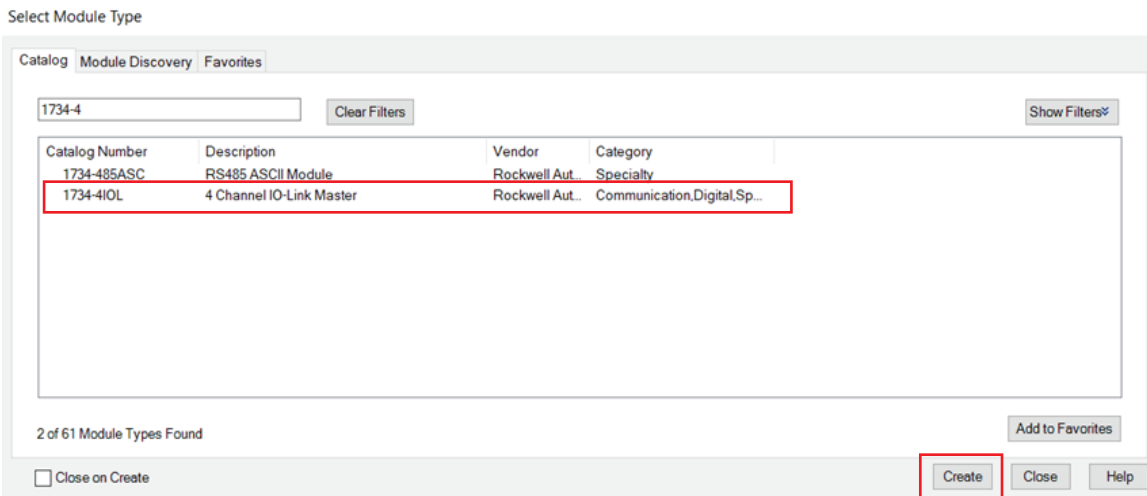

12. Another window appears to show the IO-Link Configuration screen.

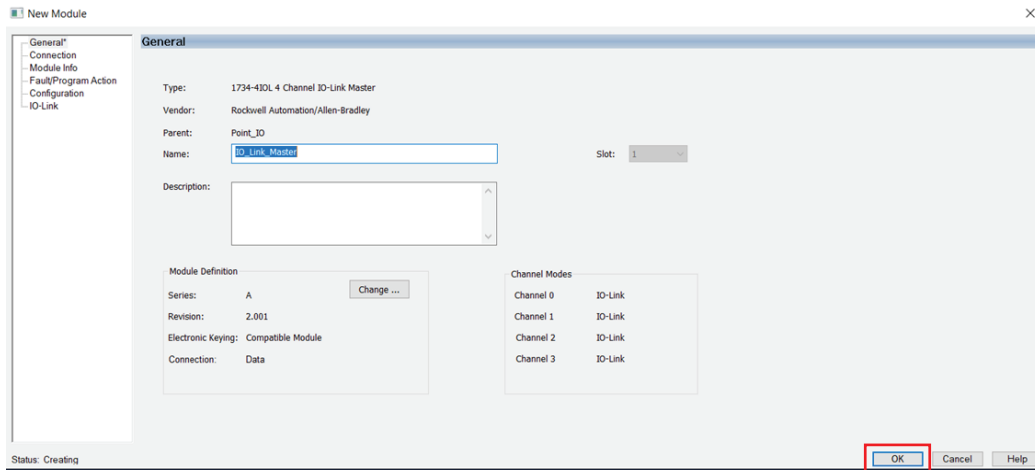

Close selection pops up window if still visible.

13. The IO-Link Master can now be configured. To configure the device, a device specific IODD (IO Device Description) file is required. The next steps show how to register the IODD file

7.6. Registration of IODD file for Power Feed 1694-PFD1244

To initialize a device on an IO-Link Master, register the IODD of the device. The IO Device Description (IODD) files contain the information that is related to the device, integrated into the system environment.

By default, the IODDs are already located in the AOP Library.

If the IODD file for the 1694-PFD1244 cannot be located in the library, it can be downloaded from: <http://compatibility.rockwellautomation.com/Pages/MultiProductDownload.aspx>.

And loaded manually to Studio5000. Once the IODD is registered, there is no need to register the IODD again unless it is manually deleted from the Master Tree.

14. Double-click the 1734-4IOL in the Controller Organizer tree in the Ethernet section

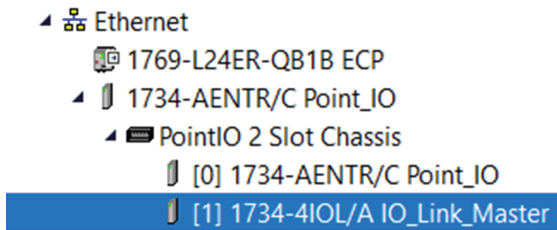

15. Properties window will be opened. Click IO-Link on the left side of the window. Screen as shown below will be displayed.

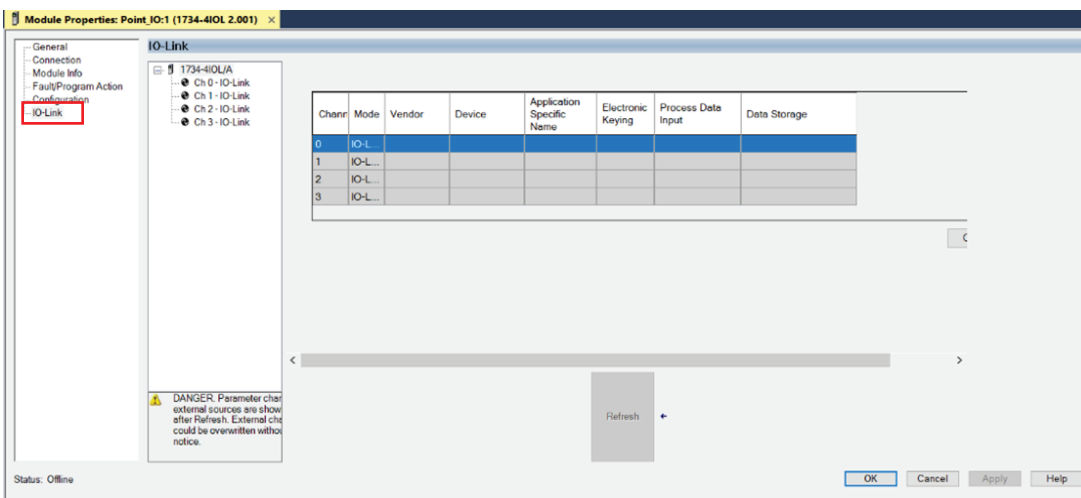

16. Right-click on the left section of the screen where the channel information is located and click “Register IODD”.

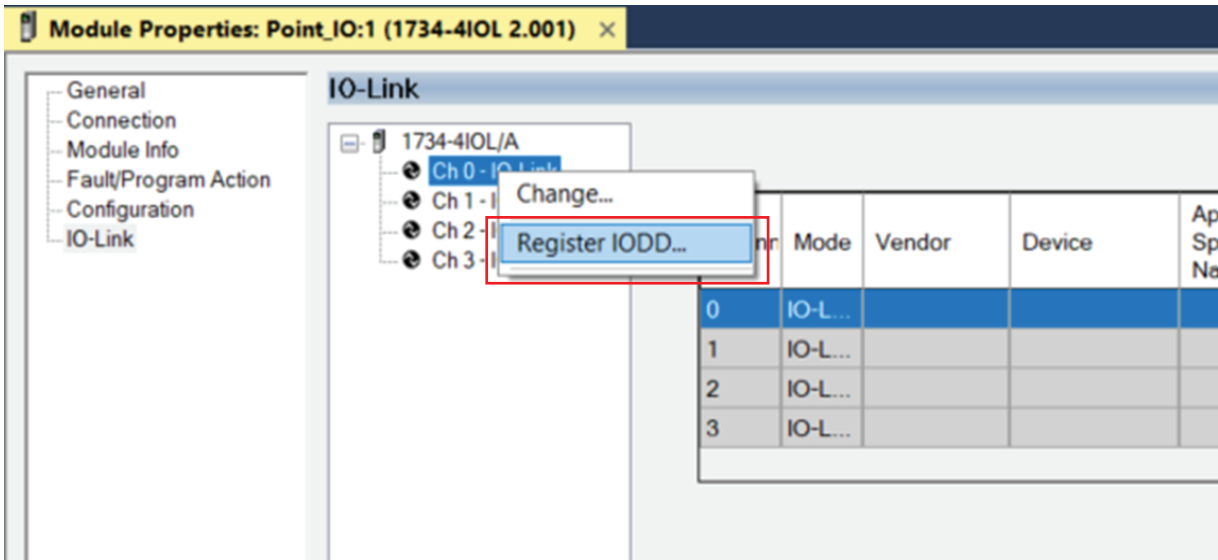

17. Select the IODD file that is needed for the device being configured and double click.

If there is no proper IODD file on the list, then press button “Register IODD” and select folder and file previously downloaded to your PC. Selected IODD will be shown on the list.

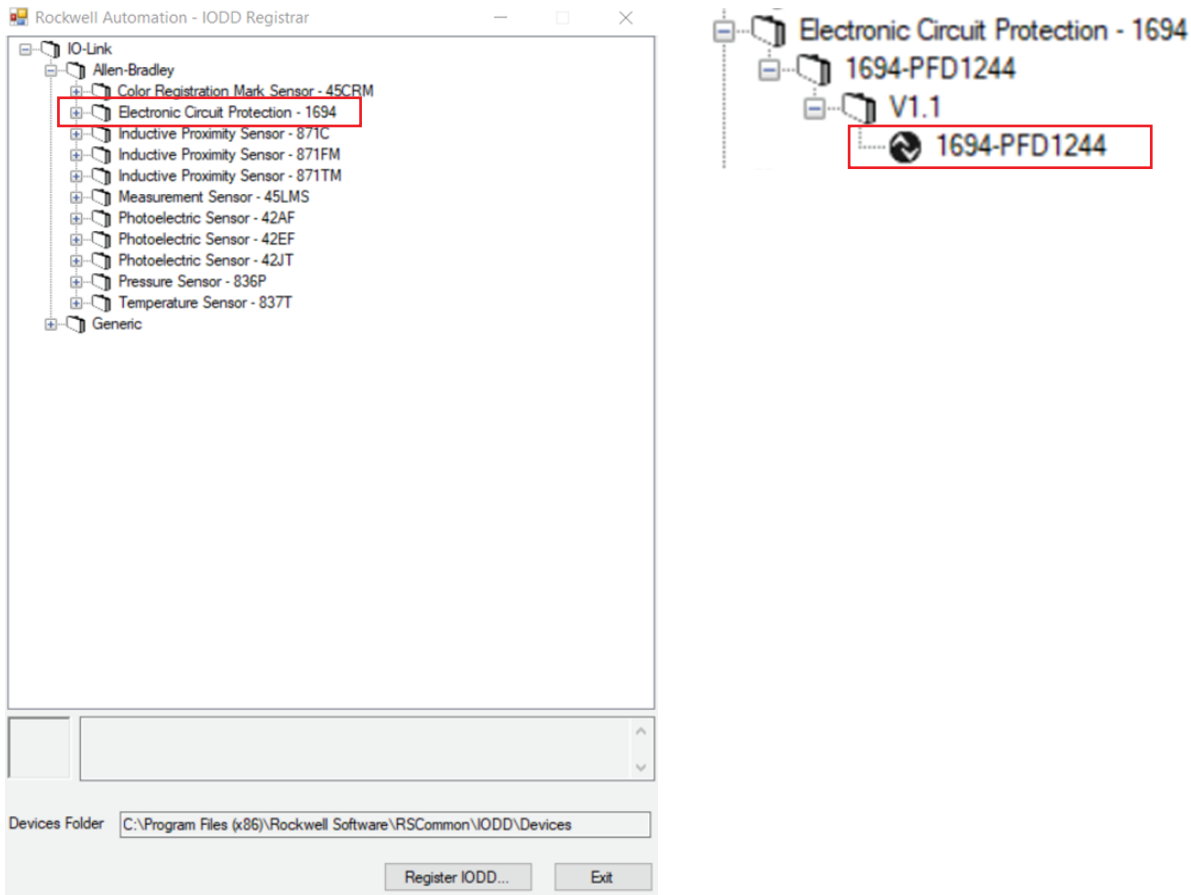

18. Then Click “Exit”

19. The IODD registration is completed.

7.7. Connect the 1694-PFD1224 to the IO-Link Master

Once the IODD file is registered, the device must be connected to the IO-Link master. The controller must always be offline to add a device to the IO-Link Master.

20. Right-click the channel number where the power feed for electronic circuit protection is configured and click “Change”

Chanr	Mode	Vendor	Device	Application Specific Name	Electronic Keying	Process Data Input	Data Storage
0	IO-L...						
1	IO-L...						
2	IO-L...						
3	IO-L...						

21. Change Channel Configuration window will appear. Then click “...” on right side of the table.

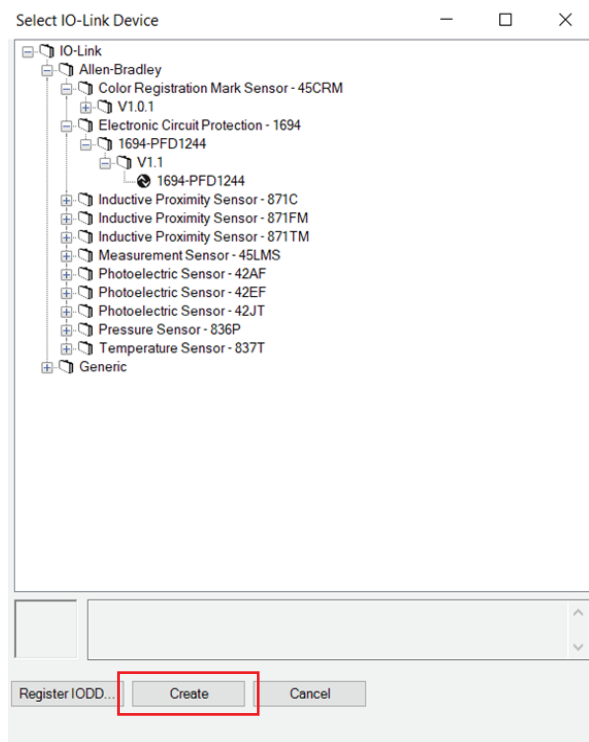
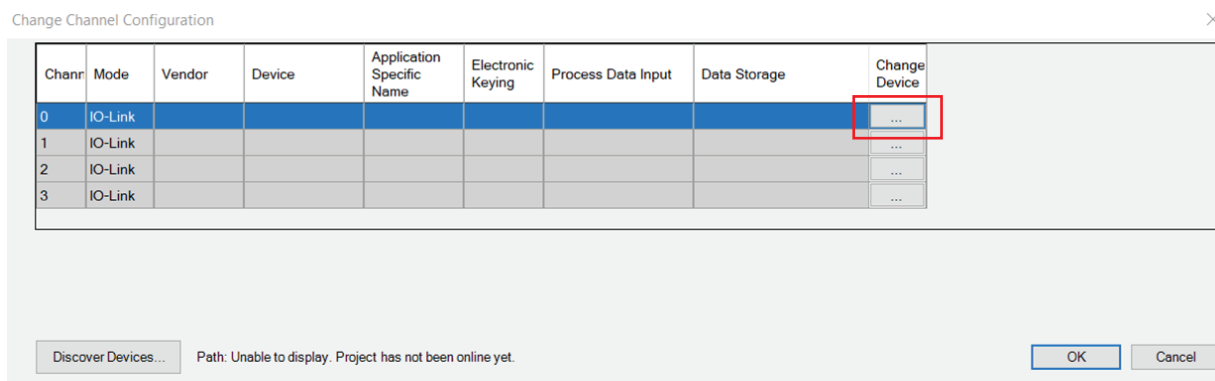

Caution: Once you click “Create” you might be required to wait longer time for configuration update. In this time Studio5000 might not react.

23. Click “Yes” to accept changes in module definition.

RSLogix 5000

Caution: you might be required to wait longer time for configuration update. In this time Studio5000 might not react.

 These changes will cause module data types and properties to change. Data will be set to default values unless it can be recovered from the existing module properties. Verify module properties before Applying changes.

Change module definition?

Yes

No

24. Press “Apply” and “OK” to accept configuration.

25. In IO-Link Tab, Check if Data Storage mode for IO-Link module is established as “Enable ADC”. If not, then user is not able to make any changes in module configuration.

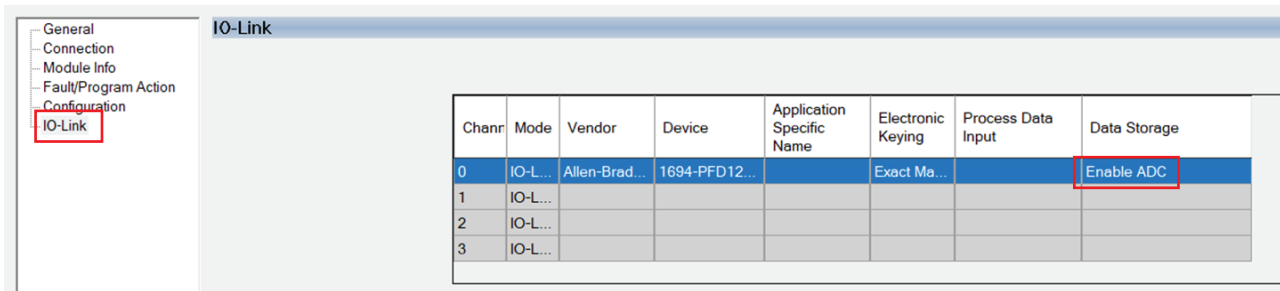

Chanr	Mode	Vendor	Device	Application Specific Name	Electronic Keying	Process Data Input	Data Storage
0	IO-L...	Allen-Brad...	1694-PFD12...		Exact Ma...		Enable ADC
1	IO-L...						
2	IO-L...						
3	IO-L...						

Now you are almost ready to go online to download the project to controller. Prior going online you must set up communication path

7.8. Download the Project to PLC

26. Setup controller communication path. Click COMMUNICATIONS on the toolbar and then “Who Active”.

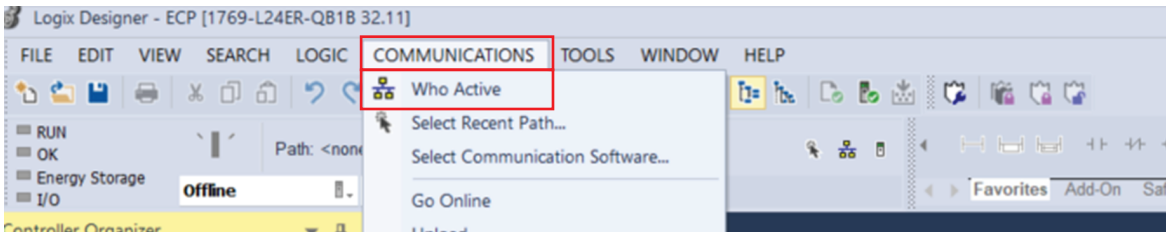

27. Select the controller that is being used for the project. In this example we are using “1769-L24ER-QB1B” CompactLogix. Once controller is selected, click “Set Project Path” and then “Go online” to start communication.

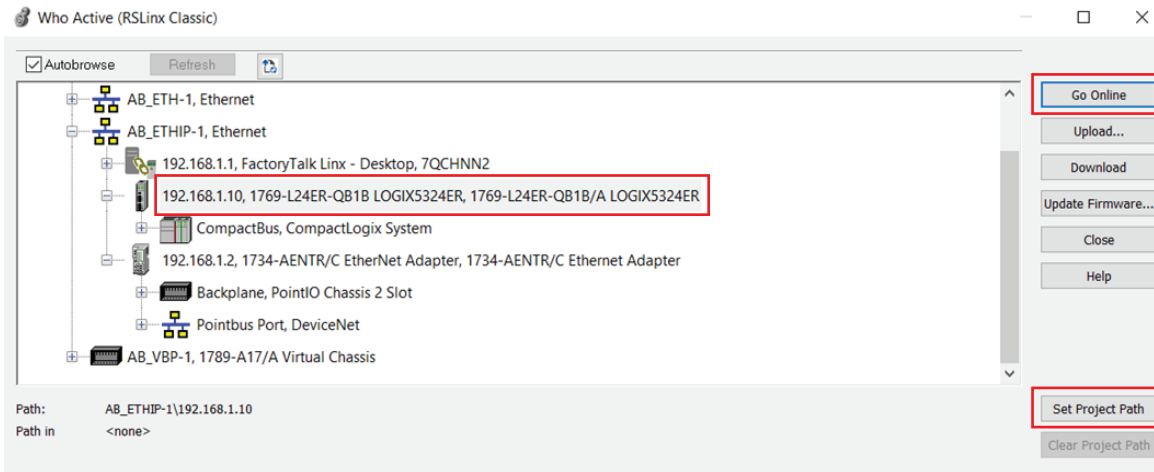

27 Installation Instructions: Bulletin 1694 Electronic circuit protection for 24V DC with IO-Link

28. Download the project to controller. Click "Download" and then confirm downloading on the next window.

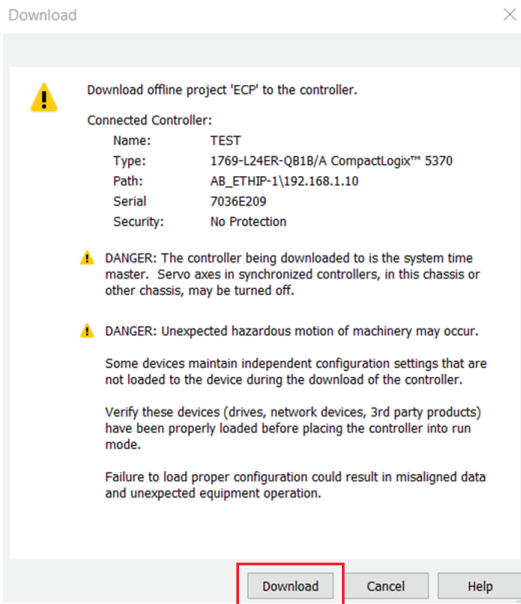
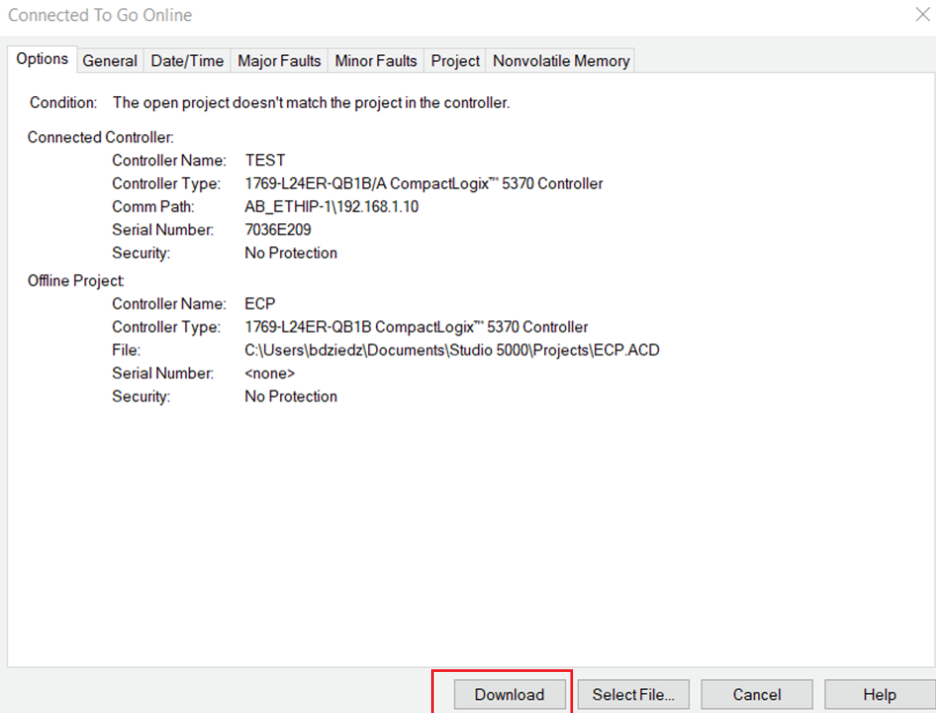

29. Project is loaded to the controller.

7.9. Exploring the 1694-PMD1244 Parameters in AOP

To display parameters of Power Feed 1694-PFD1224 and Protection Modules 1694-PMD* in AOP you need to open IO-Link Master AOP. Do to that:

1. in the Controller Organizer tree, find Ethernet under I/O Configuration and double click on IO-Link Master)

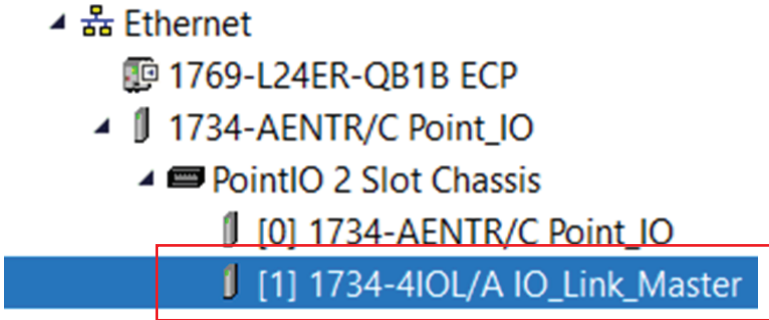

2. Properties window will be opened. Click IO-Link on the left side of the window on IO-Link description.

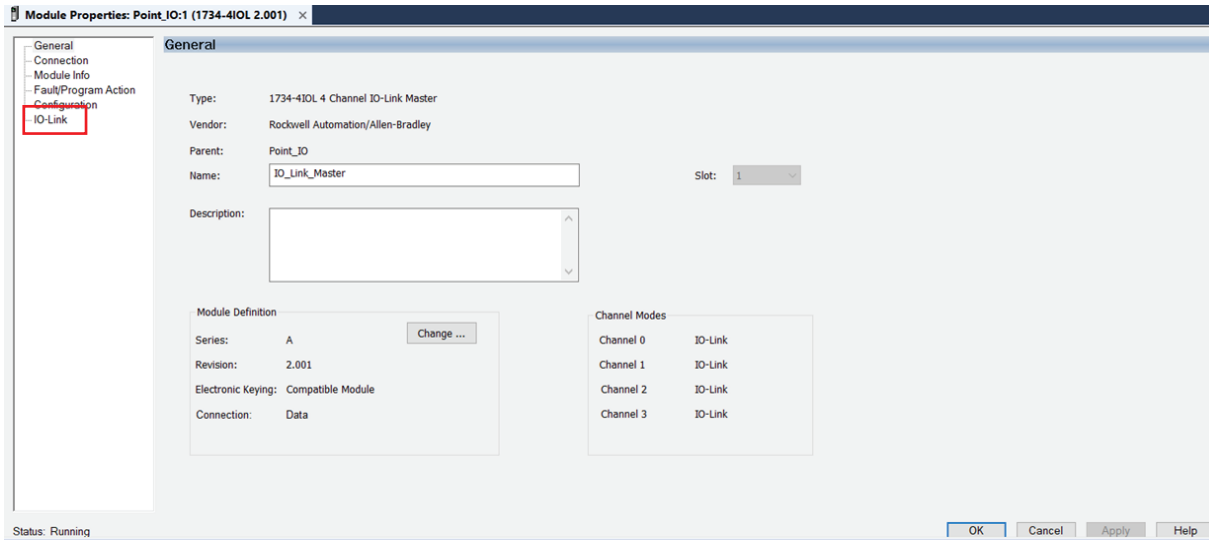

3. Then in IO-Link section click on proper channel of IO-link Master where 1694-PFD1244 module is installed (in this case this is Ch0) and click on device attached to this channel.

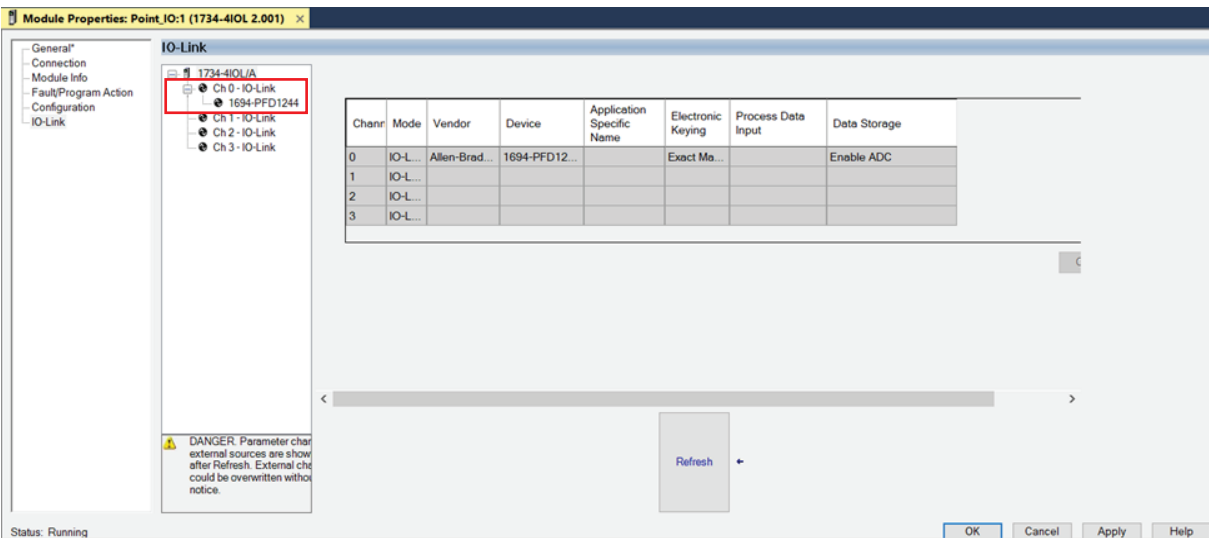

4. IO-Link overcurrent protection system parameters will be displayed

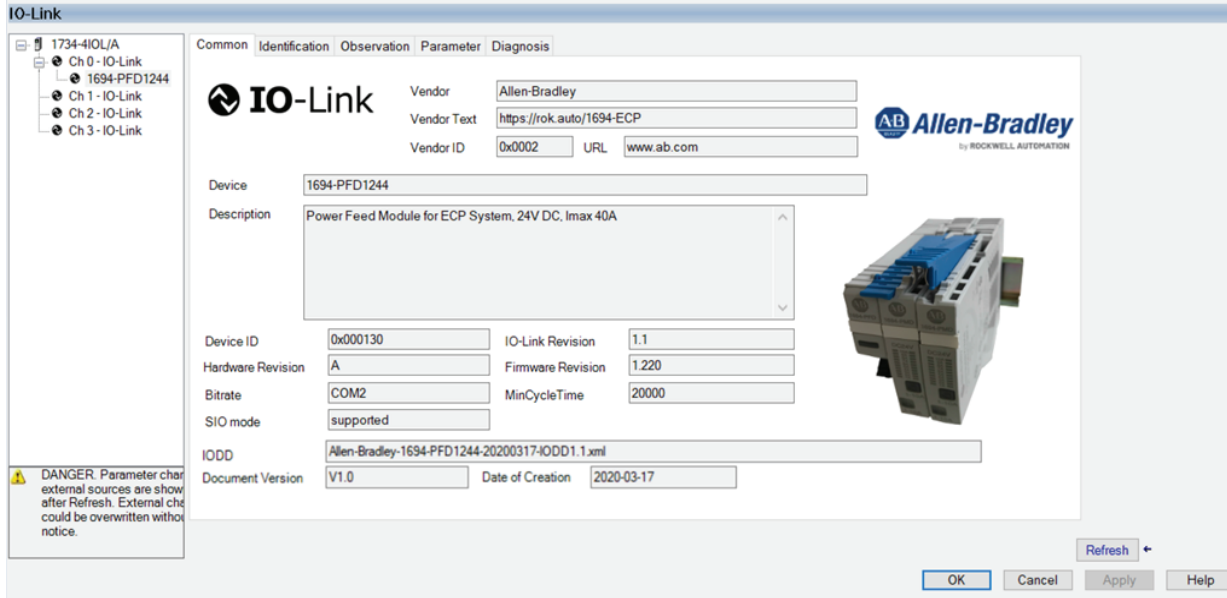

The 1694-PMD1244 offers five different tabs to describe the device functionality and operations. These tabs are:

Tab	Description
Common Tab	Provides general product information about the device specifications and IO-link IODD Information.
Identification Tab	Provides the device catalog number, series letter, general product description including the current product firmware, and hardware revisions.
Observation Tab	Provides device monitoring parameters for power feed 1694-PMD1244 and each channel controlled by Electronic Circuit Protection device.
Parameter Tab	Displays and allows you to change the device parameters offered by 1694 Electronic Circuit Protection system.
Diagnosis Tab	Diagnosis Tab displays the diagnostics parameters. Those parameters facilitate troubleshooting if device does not work correctly. In this tab, user can find features common for the all protection channels such as: Device Access Lock, Restore Factory Setting, etc.

7.9.1. Common Tab

The screenshot shows the IO-Link software interface. The left sidebar contains a tree view with the following structure:

- 1734-IOL/A
 - Ch 0 - IO-Link
 - 1694-PFD1244
 - Ch 1 - IO-Link
 - Ch 2 - IO-Link
 - Ch 3 - IO-Link

The main window displays the 'Common' tab for the selected device. The fields are as follows:

- Vendor:** Allen-Bradley
- Vendor Text:** https://rok.auto/1694-ECP
- Vendor ID:** 0x0002
- URL:** www.ab.com
- Device:** 1694-PFD1244
- Description:** Power Feed Module for ECP System, 24V DC, Imax 40A
- Device ID:** 0x000130
- IO-Link Revision:** 1.1
- Hardware Revision:** A
- Firmware Revision:** 1.220
- Bitrate:** COM2
- MinCycleTime:** 20000
- SIO mode:** supported
- IODD:** Allen-Bradley-1694-PFD1244-20200317-IODD1.1.xml
- Document Version:** V1.0
- Date of Creation:** 2020-03-17

A warning message is displayed in the bottom left corner: "DANGER Parameter changes from external sources are shown after Refresh. External changes could be overwritten without notice."

Common tab contains the following device information:

Tab	Description
Vendor	Provides the vendor name assigned to Vendor ID.
Vendor Text	Field used to describe additional product information. In this case it displays product Internet webpage address.
Vendor ID	Describes the vendor ID of the manufacturer of the product as designated in the IO-Link consortium. This is worldwide unique vendor's identifier and is assigned by the IO-Link Consortium.
URL	Displays the vendor URL.
Device	Provides the specific catalog number of the product.
Description	This parameter displays the product description.
Device ID	The parameter Device ID contains the vendor internal unique device's identifier. The Device ID is assigned by the Rockwell Automation.
IO-Link Revision	Displays the IO-Link implemented revision of protocol supported by the device.
Hardware Revision	Displays the device hardware revision number. To confirm the latest version of HW check value in Identification tab
Firmware Revision	Displays the device firmware revision number. To confirm the latest version of FW check value in Identification tab
Bitrate	Displays the IO-Link implemented communication speed supported by the device.
Minimum Cycle Time	This is device parameter to inform the master about the shortest cycle time supported by the device. Value is given in milliseconds
IODD	Displays an information about the IODD which has been used to configure the IOLD
SIO mode	Displays the information whether the IOLD support the SIO (Standard Input and Output).
Document Version	Displays information about the IODD's version which has been used to configure the IOLD
Date of Creation	This field displays date when the IODD file has been CRC stamped

7.9.2. Identification Tab

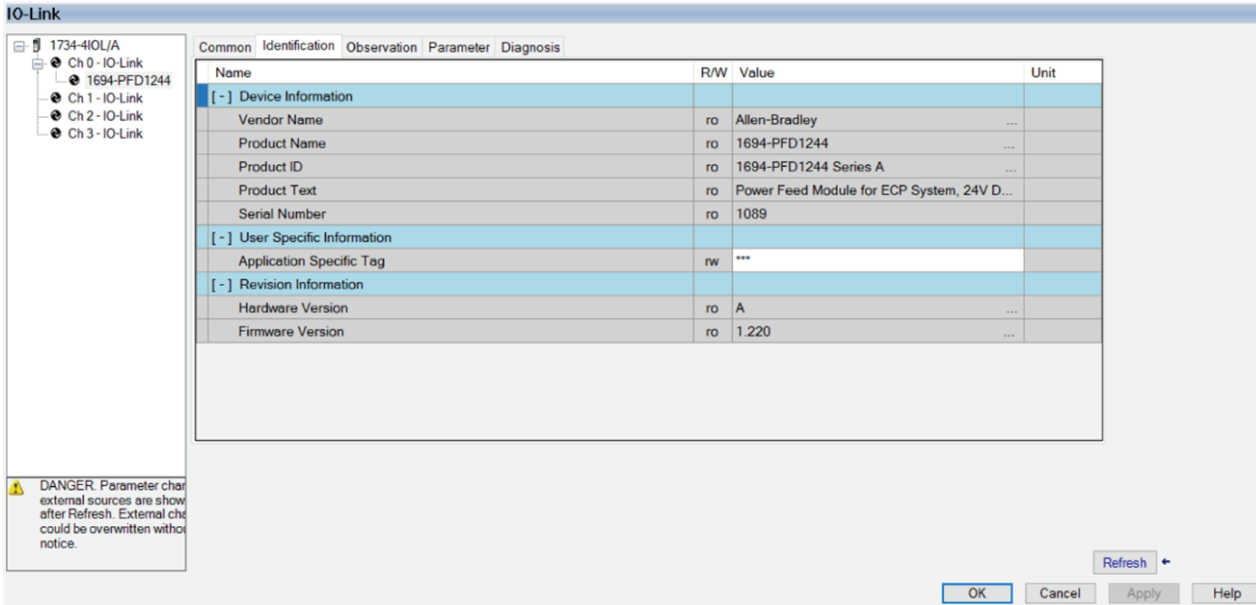

The Device Information shows us the Vendor Name, Product Name, Product Text, Product ID, and Serial Number of the exact device that is configured.

These fields automatically populate according to the device information. These fields are read-only (RO).

The User Specific Information contains the Application-Specific Name (ASN) where you can name the device with a unique text string for identification. The ASN allows a unique identity of each device. These fields can be custom (that is populated and is read/write).

Identification tab contains the following device information:

Parameter	Description
- Device Information Section	
Vendor Name	Provides the vendor name of the product. For 1694-PFD1244 this is Allen-Bradley.
Product Name	Provides the product catalog number information. For this device this is 1694-PFD1244.
Product ID	Provides product catalog number information with series letter. For this device is: 1694-PFD1244 Series A.
Product Text	Provides product (Power Feed) description.
Serial Number	Provides Power Feed serial number as unique numeric value.
- User Specific Information Section	
Application Specific Tag	Device specific name assigned to device by user for device identification. The Application Specific Tag allows a unique identity of each device. These fields can be custom (that is populated and is Read/Write).
- Revision Information Section	
Hardware Version	Hardware version of Power Feed 1694-PFD1244 provided as alphanumeric value
Firmware Version	Firmware version of Power Feed 1694-PFD1244 provided as numeric value

7.9.3. Observation Tab

Name	R/W	Value	Unit
[-] System Measurements			
Process Data In.InputVoltage	ro	24.09	V
[-] Channels Measurements			
[-] Measurements of Ch01			
Ch01 Voltage	ro	24.16	V
Process Data In.Ch01Current	ro	0	A
[-] Measurements of Ch02			
Ch02 Voltage	ro	24.16	V
Process Data In.Ch02Current	ro	0	A
[-] Measurements of Ch03			
Ch03 Voltage	ro	24.2	V
Process Data In.Ch03Current	ro	0	A
[-] Measurements of Ch04			
Ch04 Voltage	ro	24.2	V
Process Data In.Ch04Current	ro	0	A

The Device Information shows us the Vendor Name, Product Name, Product Text, Product ID, and Serial Number of the exact device that is configured.

These fields automatically populate according to the device information. These fields are read-only (RO).

The User Specific Information contains the Application-Specific Name (ASN) where you can name the device with a unique text string for identification. The ASN allows a unique identity of each device. These fields can be custom (that is populated and is read/write).

Identification tab contains the following device information:

Parameter	Description
- System Measurements Section	
Process Data In.InputVoltage	Provides power supply voltage value (line side). Unit V.
- Channels Measurements	
- Measurements of ChXX (XX=01...16)	
ChXX Voltage	Provides channel XX voltage value. Unit V.
Process Data In.ChXXCurrent	Provides channel XX current value. Unit A.
- Device Monitoring ChXX (XX=01...16)	
- Device Details	
.Device Type	Provides type of each type of Electronic Overcurrent Protection Module attached to Power Feed. It can be: <ul style="list-style-type: none"> - No Device detected, - 1-Channel module, - 2-Channel module, - Adjustable current threshold module.
.Hardware Version	Firmware version of attached Overcurrent Protection Module for channel XX control. This is provided as numeric value.
.Software Version	Software (Firmware) version of attached Overcurrent Protection Module for channel XX control. This is provided as numeric value.
.Serial Number	Serial number of attached Overcurrent Protection Module for channel XX control. This is provided as unique numeric value.

.Trip Counter	Provides number of trips for channel XX counted since first device use or last reset.
.Last Trip Type	Provides reason of last trip for channel XX. Variable can display following messages: <ul style="list-style-type: none"> - Not Triggered - Channel Short Circuit - Channel Overload - Device Internal Fault
- Statistics	
.Minimum Current	Provides value of lowest measured current for channel XX since first power ON or last device/statistics reset. Unit A.
.Maximum Current	Provides value of highest measured current for channel XX since first power ON or last device reset. Unit A.
.Average Current	Provides value of average measured current for channel XX since first power ON or last device reset. Unit A.
.Minimum Voltage	Provides value of lowest measured voltage for channel XX since first power ON or last device reset. Unit V.
.Maximum Voltage	Provides value of highest measured voltage for channel XX since first power ON or last device reset. Unit V.
.Average Voltage	Provides value of average measured voltage for channel XX since first power ON or last device reset. Unit V.

Remarks to statistical data:

- Power ON/OFF cycle does not reset the statistical data.
- Statistical values are calculated only if channel is ON.

7.9.4. Parameters Tab

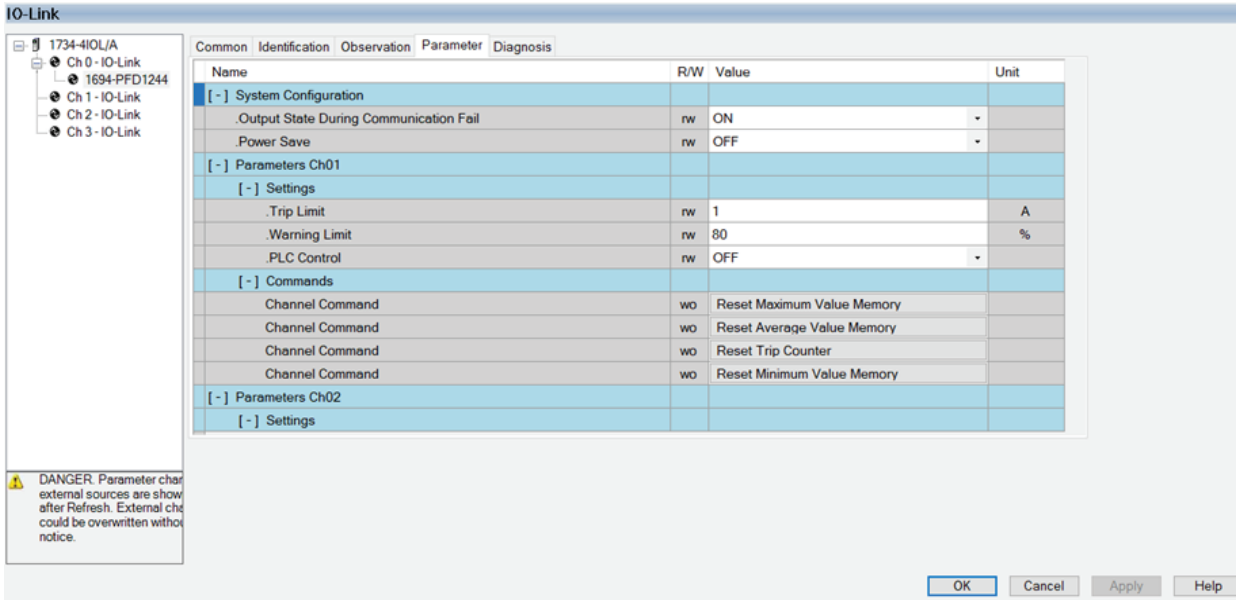

Parameters tab shows parameters that can be changed. User can define in this tab device behavior when communication is lost, warning limits, trip current, PLC control. This tab provide user with reset functions for memory fault, trip counter, statistical measurements.

Parameters tab contains the following device information:

Parameter	Description
- System Configuration	
.Output State During Communication Fail	Allows user to define the Electronic Overcurrent Protection System behavior in case of communication failed. If value is ON then outputs of all the Circuit Protectors remain in their current condition when communication is failed. If value is OFF then outputs of all the Circuit Protectors are switched OFF when communication is failed.
.Power Save	User can setup power save mode for Electronic Overcurrent Protection System. If Power Save mode in ON then LEDs shining is reduced.
- Parameters ChXX (XX=01...16)	
- Settings	
.Trip Limit	Allows user to define Current Trip Limit value for adjustable Electronic Overcurrent Protection module. When this value is exceeded in the circuit (channel XX), then device will go into trip state. For more information please refer to time/current characteristic and temperature factor table. Parameter Range: 1 to I_n . (I_n – Module Nominal Current). For non-adjustable modules, this value is read only (only for user reference). If user tries to change this parameter for non-adjustable type, then system will refuse this demand. Unit A.
.Warning Limit	Allows user to define current value (warning limit) for channel XX when the LED starts blinking (green / orange). Parameter range: 50% to 100% of Trip Limit/Nominal current. Unit %.

.PLC Control

Allows user to define if channel XX can be controlled by PLC.
When this parameter is setup as ON channel XX goes into status as described in below table.

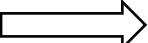
.PLC Control= OFF  .PLC Control= ON				
Initial Channel XX Status	Controller Tag .On relevant bit value responsible for channel XX ON/OFF	Color of channel XX LED button after PLC Control setup as ON	Status of XX channel after PLC Control setup as ON	Remark
ON (Green)	Bit=0	Orange	OFF (load disconnected)	
ON (Green)	Bit=1	Green	ON	
OFF (Dark)	Bit=0 or 1	Dark	OFF (load disconnected)	If in PLC Control mode, user pushes LED button to switch channel ON, then device reaction will depend on relevant bit value in Controller Tag .On

In PLC Control mode user can still control channel XX using LED module button. Device behavior when LED button is pressed in PLC Control mode is described in below table.

LED Status	Channel status	Device reaction while LED button is pressed in PLC control mode = ON
Orange	OFF	Channel status: OFF LED status: DARK PLC cannot control channel even if is in PLC control mode
Green	ON	Channel status: OFF LED status: DARK PLC cannot control channel even if is in PLC control mode Only user can switch channel ON using LED button

Comment: Channel trip reset can be done remotely from PLC independently on PLC Control mode.

- Commands

Channel Command: Reset Trip Counter [Button]	Allows user to reset trip counter for channel XX. If channel XX is controlled by 2-channels module then both channels will be reset.
Channel Command: Reset Minimum Value Memory [Button]	Allows user to reset minimum value memory of voltage and current statistics for channel XX. If channel XX is controlled by 2-channels module then both channels will be reset.
Channel Command: Reset Average Value Memory [Button]	Allows user to reset average value memory of voltage and current statistics for channel XX. If channel XX is controlled by 2-channels module then both channels will be reset.
Channel Command: Reset Maximum Value Memory [Button]	Allows user to reset maximum value memory of voltage and current statistics for channel XX. If channel XX is controlled by 2-channels module then both channels will be reset.

7.9.5. Diagnosis Tab

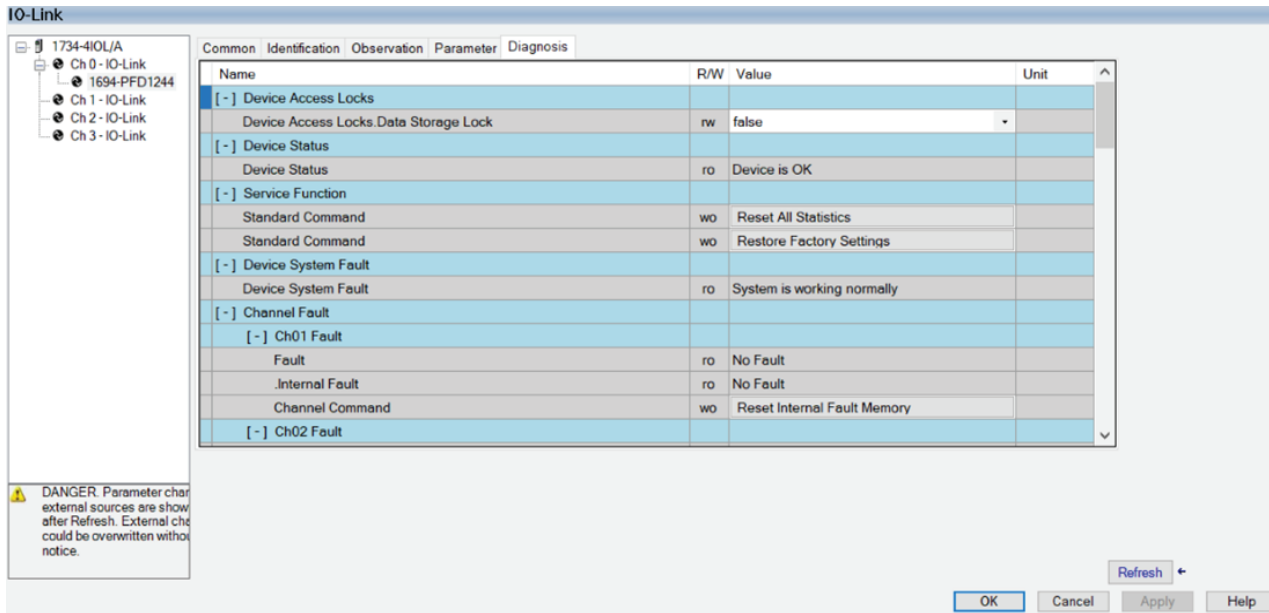

This tab provides user with device status information. User can check here potential device system faults and channel faults. In this place reset to factory settings can be done and reset of all statistical data as well. Here, user can also block device parameter changes to protect setup against unintended changes.

Diagnosis tab contains the following device information:

Parameter	Description
- Device Access Locks	
Device Access Locks.Data Storage Lock	This parameter keeps unauthorized/unintended changing the device settings (for instance: warning limits). This setting is managed by power feed and is applicable for Power Feed all protection modules in the setup. if value is “True” then change of parameters is not possible. If value is “Fales” then change of parameters is allowed.
- Device Status	
Device Status	Displays the status of device. <ul style="list-style-type: none"> - Device is OK. - Maintenance required: The Process Data are valid, internal diagnostics indicate that the Device is close to lose its ability of correct functioning. - Out of specification: The Process Data are valid, internal diagnostics indicate that the Device is operating outside its specified range or environmental conditions. - Functional check: The Process Data are temporarily invalid due to intended manipulations on the Device. This is summary diagnosis status concerning all devices in the setup.
- Service Function	
Standard Command: Reset All Statistics [Button]	Provides reset function of all statistics for all protection modules in the setup.
Standard Command: Restore Factory Settings [Button]	Provides reset to factory settings function for all devices in the setup.

- Device System Fault

Device System Fault	<p>This parameter can provide following messages:</p> <ul style="list-style-type: none"> - System is working normally. - Fault in Internal Parameter Memory detected. Disconnect and re-connect the Circuit Protector from Supply Voltage. If problem persists, please contact Rockwell Automation for further support. - Detected Device is not supported. - Internal communication was interrupted. Either there are no devices connected or they are not powered. - Watchdog Timer Reset occurred. This could be caused due to Strong Electromagnetic Interference. Try “Reset Error Memory” command. - The System has found a Fault in the Hardware. Please contact Rockwell Automation for further support. <p>This is summary diagnostic information concerning all devices in the setup.</p>
----------------------------	---

- Channel Fault

- ChXX Fault (XX = 01...16)

Fault	<p>This parameter provides message concerning channel XX fault and can provide following message types:</p> <ul style="list-style-type: none"> - No Fault. - Device is not available. - Hardware switch is in OFF position. - Undervoltage. - Overheating. - Output needs Reset. - Internal Fault. - Internal Communication Fault - Wrong Frame Length. - Internal Communication Fault - Wrong Checksum. - Device parameters changed.
--------------	---

Internal Fault	<p>This parameter provides message concerning channel XX internal fault and can provide following message types:</p> <ul style="list-style-type: none"> - No Fault - Fault in Internal Parameter Memory detected. Disconnect and re-connect the Circuit Protector from Supply Voltage. If problem persists, please contact Rockwell Automation for further support - Checksum Fault in Parameters Memory. Disconnect and re-connect the Circuit Protector from Supply Voltage. If problem persists, please contact Rockwell Automation for further support - Checksum Fault in Program Memory. Disconnect and re-connect the Circuit Protector from Supply Voltage. If problem persists, please contact Rockwell Automation for further support - Checksum Fault in Data Memory. Disconnect and re-connect the Circuit Protector from Supply Voltage. If problem persists, please contact Rockwell Automation for further support - Internal Microcontroller Fault. Disconnect and re-connect the Circuit Protector from Supply Voltage. If problem persists, please contact Rockwell Automation for further support - Watchdog Timer Reset occurred. This could be caused due to Strong Electromagnetic Interference. Try “Reset Error Memory” command - Device is not available
-----------------------	---

Channel Command: Reset Internal Fault Memory [Button]	Provides reset function of Internal Fault Memory for all channel ChXX in the setup.
--	---

- Communication Characteristics	
Direct Parameters 1.Min Cycle Time	<p>This parameter shows a device (Power Feed) parameter to inform the Master about the shortest cycle time supported by this device (Power Feed).</p> <p>Value should be decoded by user according to IO-Link Interface and System Specification Version 1.1.2. Chapter: MasterCycleTime and MinCycleTime. (Row 4136)</p>
Direct Parameters 1.Master Cycle Time	<p>This is IO-Link Master parameter and sets up the actual cycle time of a particular port in IO-Link Master.</p> <p>Value should be decoded by user according to IO-Link Interface and System Specification Version 1.1.2. Chapter: MasterCycleTime and MinCycleTime. (Row 4136)</p>
Direct Parameters 1.IO-Link Version ID	<p>Provides IO-Link version supported by Power Feed.</p>

8. Device Parameters Details

8.1. Cyclic Data

The IODD file defines the data communication between the IO link master and power feed. In detail these are the status and the load current of the electronic circuit protectors. In addition, it is possible to switch the devices on or off or reset them in the event of an anomaly. These parameters are available in Studio5000 Controller Tags. All Cyclic Data are available also using ISDU (Indexed Service Data Unit). Information required to use Cyclic Data in ISDU mode are provided in below table.

Parameter Name	Index (Dec)	Sub-Index (Dec)	Access	Default Value	Allowed Value	Data Type (length) IODD	Data Type Studio 5000
.Ch01Current	40	1	RO	0	0...25.5A (0...255)	UIntegerT (RecordT) BitLength=8 BitOffset=232	Int
.Ch02Current	40	2	RO	0	0...25.5A (0...255)	UIntegerT (RecordT) BitLength=8 BitOffset=224	Int
.Ch03Current	40	3	RO	0	0...25.5A (0...255)	UIntegerT (RecordT) BitLength=8 BitOffset=216	Int
.Ch04Current	40	4	RO	0	0...25.5A (0...255)	UIntegerT (RecordT) BitLength=8 BitOffset=208	Int
.Ch05Current	40	5	RO	0	0...25.5A (0...255)	UIntegerT (RecordT) BitLength=8 BitOffset=200	Int
.Ch06Current	40	6	RO	0	0...25.5A (0...255)	UIntegerT (RecordT) BitLength=8 BitOffset=192	Int
.Ch07Current	40	7	RO	0	0...25.5A (0...255)	UIntegerT (RecordT) BitLength=8 BitOffset=184	Int
.Ch08Current	40	8	RO	0	0...25.5A (0...255)	UIntegerT (RecordT) BitLength=8 BitOffset=176	Int
.Ch09Current	40	9	RO	0	0...25.5A (0...255)	UIntegerT (RecordT) BitLength=8 BitOffset=168	Int
.Ch10Current	40	10	RO	0	0...25.5A (0...255)	UIntegerT (RecordT) BitLength=8 BitOffset=160	Int
.Ch11Current	40	11	RO	0	0...25.5A (0...255)	UIntegerT (RecordT) BitLength=8 BitOffset=152	Int
.Ch12Current	40	12	RO	0	0...25.5A (0...255)	UIntegerT (RecordT) BitLength=8 BitOffset=144	Int
.Ch13Current	40	13	RO	0	0...25.5A (0...255)	UIntegerT (RecordT) BitLength=8 BitOffset=136	Int
.Ch14Current	40	14	RO	0	0...25.5A (0...255)	UIntegerT (RecordT) BitLength=8 BitOffset=128	Int
.Ch15Current	40	15	RO	0	0...25.5A (0...255)	UIntegerT (RecordT) BitLength=8 BitOffset=120	Int
.Ch16Current	40	16	RO	0	0...25.5A (0...255)	UIntegerT (RecordT) BitLength=8 BitOffset=112	Int

.Status	40	17	RO	0	<p>Bit 0 = Channel 01 On/Off Bit 1 = Channel 02 On/Off Bit 2 = Channel 03 On/Off Bit 3 = Channel 04 On/Off Bit 4 = Channel 05 On/Off Bit 5 = Channel 06 On/Off Bit 6 = Channel 07 On/Off Bit 7 = Channel 08 On/Off Bit 8 = Channel 09 On/Off Bit 9 = Channel 10 On/Off Bit 10 = Channel 11 On/Off Bit 11 = Channel 12 On/Off Bit 12 = Channel 13 On/Off Bit 13 = Channel 14 On/Off Bit 14 = Channel 15 On/Off Bit 15 = Channel 16 On/Off</p> <p>For Status=On Bit Value = 1 For Status=Off Bit value = 0</p> <p><i>Comment: Shows the Channel Status of the Device installed. One bit each representing the status of a separate channel.</i></p>	IntegerT (RecordT) BitLength=16 BitOffset=96	Int
.OverLoad	40	18	RO	0	<p>Bit 0 = Channel 01 Overload Bit 1 = Channel 02 Overload Bit 2 = Channel 03 Overload Bit 3 = Channel 04 Overload Bit 4 = Channel 05 Overload Bit 5 = Channel 06 Overload Bit 6 = Channel 07 Overload Bit 7 = Channel 08 Overload Bit 8 = Channel 09 Overload Bit 9 = Channel 10 Overload Bit 10 = Channel 11 Overload Bit 11 = Channel 12 Overload Bit 12 = Channel 13 Overload Bit 13 = Channel 14 Overload Bit 14 = Channel 15 Overload Bit 15 = Channel 16 Overload</p> <p>For Overload=Yes Bit Value = 1 For Overload=No Bit Value = 0</p> <p><i>Comment: Shows the Channel overload status. One bit each representing the status of a separate channel</i></p>	IntegerT (RecordT) BitLength=16 BitOffset=80	Int
.ShortCircuit	40	19	RO	0	<p>Bit 0 = Channel 01 Short Circuit Bit 1 = Channel 02 Short Circuit Bit 2 = Channel 03 Short Circuit Bit 3 = Channel 04 Short Circuit Bit 4 = Channel 05 Short Circuit Bit 5 = Channel 06 Short Circuit Bit 6 = Channel 07 Short Circuit Bit 7 = Channel 08 Short Circuit Bit 8 = Channel 09 Short Circuit Bit 9 = Channel 10 Short Circuit Bit 10 = Channel 11 Short Circuit Bit 11 = Channel 12 Short Circuit Bit 12 = Channel 13 Short Circuit Bit 13 = Channel 14 Short Circuit Bit 14 = Channel 15 Short Circuit Bit 15 = Channel 16 Short Circuit</p> <p>For Short Circuit =Yes, Bit Value = 1 For Short Circuit =No, Bit Value = 0</p> <p><i>Comment: Shows the Channel short circuit status. One bit each representing the status of a separate channel</i></p>	IntegerT (RecordT) BitLength=16 BitOffset=64	Int

.WarningLimit	40	20	RO	0	<p>Bit 0 = Channel 01 Current Warning Limit Bit 1 = Channel 02 Current Warning Limit Bit 2 = Channel 03 Current Warning Limit Bit 3 = Channel 04 Current Warning Limit Bit 4 = Channel 05 Current Warning Limit Bit 5 = Channel 06 Current Warning Limit Bit 6 = Channel 07 Current Warning Limit Bit 7 = Channel 08 Current Warning Limit Bit 8 = Channel 09 Current Warning Limit Bit 9 = Channel 10 Current Warning Limit Bit 10 = Channel 11 Current Warning Limit Bit 11 = Channel 12 Current Warning Limit Bit 12 = Channel 13 Current Warning Limit Bit 13 = Channel 14 Current Warning Limit Bit 14 = Channel 15 Current Warning Limit Bit 15 = Channel 16 Current Warning Limit</p> <p>For current above warning limit =Yes, Bit Value = 1 For current above warning limit =No, Bit Value = 0</p> <p><i>Comment: Shows the Channel current warning limit status. One bit each representing the status of a separate channel</i></p>	IntegerT (RecordT) BitLength=16 BitOffset=48	Int
.HardwareLock	40	21	RO	0	<p>Bit 0 = Channel 01 Hardware button on housing switched off Bit 1 = Channel 02 Hardware button on housing switched off Bit 2 = Channel 03 Hardware button on housing switched off Bit 3 = Channel 04 Hardware button on housing switched off Bit 4 = Channel 05 Hardware button on housing switched off Bit 5 = Channel 06 Hardware button on housing switched off Bit 6 = Channel 07 Hardware button on housing switched off Bit 7 = Channel 08 Hardware button on housing switched off Bit 8 = Channel 09 Hardware button on housing switched off Bit 9 = Channel 10 Hardware button on housing switched off Bit 10 = Channel 11 Hardware button on housing switched off Bit 11 = Channel 12 Hardware button on housing switched off Bit 12 = Channel 13 Hardware button on housing switched off Bit 13 = Channel 14 Hardware button on housing switched off Bit 14 = Channel 15 Hardware button on housing switched off Bit 15 = Channel 16 Hardware button on housing switched off</p> <p>For Hardware button = ON Bit Value = 0 For Hardware button = OFF Bit Value = 1</p> <p><i>Comment: Shows the Channel Hardware button status. One bit each representing the status of a separate channel</i></p>	IntegerT (RecordT) BitLength=16 BitOffset=32	Int
.GeneralStatus	40	22	RO	<p>Bit 0 = 0 Bit 1 = 1 – when communication established</p>	<p>Bit 0 = Input Voltage fell below the value indicated in the Data Sheet</p> <p>Value = 0 means NOT undervoltage detected Value= 1 means undervoltage detected</p> <p>Bit 1 = Always set to 1. Can be used for anomaly detection of the IO-Link connection</p> <p>Remining bits are dummy and are not used. Were put in for reasons of compatibility.</p>	UIntegerT (RecordT) BitLength=8 BitOffset=24	Int

.InputVoltage	40	24	RO	0	0...30V (0...3000)	IntegerT (RecordT) BitLength=16 BitOffset=0	Int
.TripReset	41	1	WO	0	<p>Bit 0 = Channel 01 Trip Reset Bit 1 = Channel 02 Trip Reset Bit 2 = Channel 03 Trip Reset Bit 3 = Channel 04 Trip Reset Bit 4 = Channel 05 Trip Reset Bit 5 = Channel 06 Trip Reset Bit 6 = Channel 07 Trip Reset Bit 7 = Channel 08 Trip Reset Bit 8 = Channel 09 Trip Reset Bit 9 = Channel 10 Trip Reset Bit 10 = Channel 11 Trip Reset Bit 11 = Channel 12 Trip Reset Bit 12 = Channel 13 Trip Reset Bit 13 = Channel 14 Trip Reset Bit 14 = Channel 15 Trip Reset Bit 15 = Channel 16 Trip Reset</p> <p>If bit value setup as 1 channel reset will be done</p> <p><i>Comment: Provides the Channel remote reset from PLC. One bit each representing the reset function of a separate channel</i></p>	IntegerT (RecordT) BitLength=16 BitOffset=16	Int
.On	41	2	WO	0	<p>Bit 0 = Channel 01 On/Off Bit 1 = Channel 02 On/Off Bit 2 = Channel 03 On/Off Bit 3 = Channel 04 On/Off Bit 4 = Channel 05 On/Off Bit 5 = Channel 06 On/Off Bit 6 = Channel 07 On/Off Bit 7 = Channel 08 On/Off Bit 8 = Channel 09 On/Off Bit 9 = Channel 10 On/Off Bit 10 = Channel 11 On/Off Bit 11 = Channel 12 On/Off Bit 12 = Channel 13 On/Off Bit 13 = Channel 14 On/Off Bit 14 = Channel 15 On/Off Bit 15 = Channel 16 On/Off</p> <p>If bit value setup as 0 channel will be switched OFF If bit value setup as 1 channel will be switched ON</p> <p><i>Comment: Provides the Channel remote switch OFF/ON from PLC. One bit each representing the switch OFF/ON function of a separate channel.</i></p> <p>Attention: This function is available when .PLC Control parameter is setup as "ON" for given channel.</p>	IntegerT (RecordT) BitLength=16 BitOffset=0	Int

8.2. Non-Cyclic Data

The non-cyclical data communication (ISDU) allows exchange of more information between the PLC and the circuit protection units via power feed than using the limited cyclical range. Depending on the selected index, a varying number of data bytes are exchanged in the non-cyclical data traffic. The table below provides an overview over the parameter ranges and functions related to them.

Parameter Name	Index (Dec)	Sub-Index (Dec)	Access	Default Value	Allowed Value	Data Type (length, Offset) IODD	Data Type Studio 5000
Direct Parameters 1.Master Cycle Time	0	2	RO	Please refer to: IO-Link Interface and System Specification Version 1.1.2. Value should be decoded by user according to IO-Link Interface and System Specification Version 1.1.2. Chapter: B.1.3 MasterCycleTime and MinCycleTime.		UIntegerT (RecordT) BitLength=8 BitOffset=112	Dint
Direct Parameters 1.Min Cycle Time	0	3	RO	Please refer to: IO-Link Interface and System Specification Version 1.1.2. Value should be decoded by user according to IO-Link Interface and System Specification Version 1.1.2. Chapter: B.1.3 MasterCycleTime and MinCycleTime.		UIntegerT (RecordT) BitLength=8 BitOffset=104	Dint
Direct Parameters 1.IO-Link Version ID	0	5	RO	Provides IO-Link version supported by Power Feed.		UIntegerT (RecordT) BitLength=8 BitOffset=96	Int
System Command	2	0	WO		130 = Reset Factory Settings 250 = Reset All Statistics	UIntegerT BitLength=8	Int
Device Access Locks.Data Storage Lock	12	2	RW	False	TRUE = Data Storage Locked FALSE = Data Storage Unlocked	BoolT (RecordT) BitLength=1 BitOffset=1	Bool
Vendor Name	16	0	RO	Allen-Bradley		StringT BitLength=64 bytes	String
Product Name	18	0	RO	1694-PFD1244		StringT BitLength=64 bytes	String
Product ID	19	0	RO	1694-PFD1244 Series A		StringT BitLength=64 bytes	String
Product Text	20	0	RO	Power Feed Module for ECP System, 24V DC, I _{max} 40A		StringT BitLength=64 bytes	String
Serial Number	21	0	RO	<i>Comment: serial number of Power Feed</i>		StringT BitLength=16 bytes	String
Hardware Version	22	0	RO	A		StringT BitLength=64 bytes	String
Firmware Version	23	0	RO	1.220 <i>Comment: FW version of Power Feed</i>		StringT BitLength=64 bytes	String
Application Specific Tag	24	0	RW		Text string. Max 32 characters	StringT BitLength=32 bytes	String
Device Status	36	0	RO	0	0 = Device is OK 1 = Maintenance required 2 = Out of specification 3 = Functional check	UIntegerT BitLength=8	Sint
Settings	1XX	0	RW			RecordT BitLength=16	

XX= Channel number (01...16). Variable indexes from 101 to 116

.Trip Limit	1XX	1	RW	0	1...10 A (1...10)	UIntegerT (RecordT) BitLength=16 BitOffset=8	Sint
.Warning Limit	1XX	2	RW	80	50..100% (50...100)	UIntegerT (RecordT) BitLength=16 BitOffset=0	Sint
Ch01 PLC Control	199	1	RW	Ture	True = Channel is NOT controlled by PLC False = Channel is controlled by PLC	BoolT (RecordT) BitLength=1 BitOffset=1	Bool
Ch02 PLC Control	199	2	RW	True	True = Channel is NOT controlled by PLC False = Channel is controlled by PLC	BoolT (RecordT) BitLength=1 BitOffset=2	Bool
Ch03 PLC Control	199	3	RW	True	True = Channel is NOT controlled by PLC False = Channel is controlled by PLC	BoolT (RecordT) BitLength=1 BitOffset=3	Bool
Ch04 PLC Control	199	4	RW	True	True = Channel is NOT controlled by PLC False = Channel is controlled by PLC	BoolT (RecordT) BitLength=1 BitOffset=4	Bool
Ch05 PLC Control	199	5	RW	True	True = Channel is NOT controlled by PLC False = Channel is controlled by PLC	BoolT (RecordT) BitLength=1 BitOffset=5	Bool
Ch06 PLC Control	199	6	RW	True	True = Channel is NOT controlled by PLC False = Channel is controlled by PLC	BoolT (RecordT) BitLength=1 BitOffset=6	Bool
Ch07 PLC Control	199	7	RW	True	True = Channel is NOT controlled by PLC False = Channel is controlled by PLC	BoolT (RecordT) BitLength=1 BitOffset=7	Bool
Ch08 PLC Control	199	8	RW	True	True = Channel is NOT controlled by PLC False = Channel is controlled by PLC	BoolT (RecordT) BitLength=1 BitOffset=8	Bool
Ch09 PLC Control	199	9	RW	True	True = Channel is NOT controlled by PLC False = Channel is controlled by PLC	BoolT (RecordT) BitLength=1 BitOffset=9	Bool
Ch10 PLC Control	199	10	RW	True	True = Channel is NOT controlled by PLC False = Channel is controlled by PLC	BoolT (RecordT) BitLength=1 BitOffset=10	Bool
Ch11 PLC Control	199	11	RW	True	True = Channel is NOT controlled by PLC False = Channel is controlled by PLC	BoolT (RecordT) BitLength=1 BitOffset=11	Bool
Ch12 PLC Control	199	12	RW	True	True = Channel is NOT controlled by PLC False = Channel is controlled by PLC	BoolT (RecordT) BitLength=1 BitOffset=12	Bool
Ch13 PLC Control	199	13	RW	True	True = Channel is NOT controlled by PLC False = Channel is controlled by PLC	BoolT (RecordT) BitLength=1 BitOffset=13	Bool
Ch014PLC Control	199	14	RW	True	True = Channel is NOT controlled by PLC False = Channel is controlled by PLC	BoolT (RecordT) BitLength=1 BitOffset=14	Bool
Ch015PLC Control	199	15	RW	True	True = Channel is NOT controlled by PLC False = Channel is controlled by PLC	BoolT (RecordT) BitLength=1 BitOffset=15	Bool
Ch16 PLC Control	199	16	RW	True	True = Channel is NOT controlled by PLC False = Channel is controlled by PLC	BoolT (RecordT) BitLength=1 BitOffset=16	Bool
.Output State During Communication Fail	200	1	RW	True	True = (Selector ON) Outputs of all the Circuit Protectors remain in their current condition False = (Selector OFF) Outputs of all the Circuit Protectors are switched OFF	BooleanT (RecordT) BitLength=1 BitOffset=1	Bool
.Power Save	200	2	RW	False	True = Power Safe ON False = Power Safe OFF	BooleanT (RecordT) BitLength=1 BitOffset=2	Bool

Device System Fault	300	0	RO	0	<p>0 = System is working normally</p> <p>1 = Fault in Internal Parameter Memory detected. Disconnect and re-connect the Circuit Protector from Supply Voltage. If problem persists, please contact Rockwell Automation for further support</p> <p>2 = Detected Device is not supported</p> <p>128 = Internal communication was interrupted. Either there are no devices connected or they are not powered</p> <p>512 = Watchdog Timer Reset occurred. This could be caused due to Strong Electromagnetic Interference. Try "Reset Error Memory" command</p> <p>1024 = The System has found a Fault in the Hardware. Please contact Rockwell Automation for further support</p>	UIntegerT BitLength=16	Int
ChXX Fault	3XX		RO	0	<p>0 = No Fault</p> <p>2 = Device is not available</p> <p>146 =Hardware switch is in OFF position</p> <p>147 =Undervoltage</p> <p>148 =Overheating</p> <p>149 =Output needs Reset</p> <p>152 =Internal Fault</p> <p>154 = Internal Communication Fault - Wrong Frame Length</p> <p>155 = Internal Communication Fault - Wrong Checksum</p> <p>156 =Device parameters changed</p>	UIntegerT BitLength=8	Int

XX= Channel number (01...16). Variable indexes from 301 to 316

ChXX Voltage	4XX	0	RO	0	0...30.0 V (0...3000)	UIntegerT BitLength=16	Int
--------------	-----	---	----	---	-----------------------	---------------------------	-----

XX= Channel number (01...16). Variable indexes from 401 to 416

ChXX Operation Information	5XX	0	RO			RecordT BitLength=24	
----------------------------	-----	---	----	--	--	-------------------------	--

XX= Channel number (01...16). Variable indexes from 501 to 516

.Internal Fault	5XX	1	RO	0	<p>0 = No Fault</p> <p>1 = Fault in Internal Parameter Memory detected. Disconnect and re-connect the Circuit Protector from Supply Voltage. If problem persists, please contact Rockwell Automation for further support</p> <p>2 = Checksum Fault in Parameters Memory. Disconnect and re-connect the Circuit Protector from Supply Voltage. If problem persists, please contact Rockwell Automation for further support</p> <p>4 = Checksum Fault in Program Memory. Disconnect and re-connect the Circuit Protector from Supply Voltage. If problem persists, please contact Rockwell Automation for further support</p> <p>8 = Checksum Fault in Data Memory. Disconnect and re-connect the Circuit Protector from Supply Voltage. If problem persists, please contact Rockwell Automation for further support</p> <p>16 = Internal Microcontroller Fault. Disconnect and re-connect the Circuit Protector from Supply Voltage. If problem persists, please contact Rockwell Automation for further support</p> <p>32 =Watchdog Timer Reset occurred. This could be caused due to Strong Electromagnetic Interference. Try "Reset Error Memory" command</p> <p>128 = Device is not available</p>	UIntegerT (RecordT) BitLength=8 BitOffset=16	Int
.Trip Counter	5XX	2	RO	0	0...255	UIntegerT (RecordT) BitLength=8 BitOffset=8	Int

.Last Trip Type	5XX	3	RO	0	0 = Not Triggered 1 = Channel Short Circuit 2 = Channel Overload 4 = Device Internal Fault	UIntegerT (RecordT) BitLenght=8 BitOffset=0	Sint
ChXX Device Details	7XX	0	RO			RecordT BitLenght=80	

XX= Channel number (01...16). Variable indexes from 701 to 716

.Device Type	7XX	1	RO	0	0 = No Device Detected. Either there are no Devices, or they are not powered 36873 = 1694 IO-Link With 1 Channel, Fixed Current Threshold 36874 = 1694 IO-Link With 2 Channel, Fixed Current Threshold 36875 = 1694 IO-Link With 4 Channel, Fixed Current Threshold 36878 = 1694 IO-Link With 2 Channels, Adjustable Current Threshold	UIntegerT (RecordT) BitLenght=16 BitOffset=0	Dint
.Hardware Version	7XX	2	RO		Numeric Value depending on Protection Module type and its HW version.	UIntegerT (RecordT) BitLenght=16 BitOffset=16	Int
.Software Version	7XX	3	RO		Numeric Value depending on Protection Module type and its FW version. <i>Comment: For empty channels (where protection module is not attached value =-0.6 is shown as the result of calculations demanded in IODD)</i>	UIntegerT (RecordT) BitLenght=16 BitOffset=32	Int
.Serial Number	7XX	4	RO		<i>Comment: Serial number of Protection Module.</i>	UIntegerT (RecordT) BitLenght=32 BitOffset=48	Dint
ChXX Statistics	8XX	0	RO			RecordT BitLenght=96	

XX= Channel number (01...16). Variable indexes from 501 to 516

.Minimum Current	8XX	1	RO		0...655.35 A (0...65535)	UIntegerT (RecordT) BitLenght=16 BitOffset=0	Dint
.Maximum Current	8XX	2	RO		0...655.35 A (0...65535)	UIntegerT (RecordT) BitLenght=16 BitOffset=16	Dint
.Average Current	8XX	3	RO		0...655.35 A (0...65535)	UIntegerT (RecordT) BitLenght=16 BitOffset=32	Dint
.Minimum Voltage	8XX	4	RO		0...655.35 V (0...65535)	UIntegerT (RecordT) BitLenght=16 BitOffset=48	Dint
.Maximum Voltage	8XX	5	RO		0...655.35 V (0...65535)	UIntegerT (RecordT) BitLenght=16 BitOffset=64	Dint
.Average Voltage	8XX	6	RO		0...655.35 V (0...65535)	UIntegerT (RecordT) BitLenght=16 BitOffset=80	Dint

Studio5000 Data Type is a recommended data type to be used in user PLC program. For more information please refer to Programming Manuals: Logix 5000 Controllers I/O and Tag Data 1756-PM004 or Logix 5000 Controllers Data Access 1756-PM020 and IO-Link technology specifications available on IO-Link community webpage: www.io-link.com

9. Rockwell Automation Support

Rockwell Automation maintains current product environmental information on its website at:

<http://www.rockwellautomation.com/rockwellautomation/about-us/sustainability-ethics/product-environmental-compliance.page>





Installation Instructions, Manuals, Brochures, and Technical Data:

<https://www.rockwellautomation.com/global/literature-library/overview.page>

Bulletin 1694 web page:

<https://rok.auto/1694-ECP>

For the latest product information updates please check above links or www.rockwellautomation.com

Connect with us.    

For Technical Support, visit ROK.AUTO/SUPPORT.

Rockwell Automation maintains current product environmental compliance information on its website at rok.auto/pec.

Rockwell Otomasyon Ticaret A.Ş. Kar Plaza İş Merkezi E Blok Kat:6 34752 İçerenköy, İstanbul, Tel: +90 (216) 5698400
EEE Yönetmeliğine Uygundur

rockwellautomation.com

expanding **human possibility**[™]

AMERICAS: Rockwell Automation, 1201 South Second Street, Milwaukee, WI 53204-2496 USA, Tel: (1) 414.382.2000, Fax: (1) 414.382.4444

EUROPE/MIDDLE EAST/AFRICA: Rockwell Automation NV, Pegasus Park, De Kleetlaan 12a, 1831 Diegem, Belgium, Tel: (32) 2 663 0600, Fax: (32) 2 663 0640

ASIA PACIFIC: Rockwell Automation, Level 14, Core F, Cyberport 3, 100 Cyberport Road, Hong Kong, Tel: (852) 2887 4788, Fax: (852) 2508 1846

Allen-Bradley, Rockwell Automation, and Rockwell Software are trademarks of Rockwell Automation.
Trademarks not belonging to Rockwell Automation are property of their respective companies.

Publication 1694-IN001B-EN-E - August 2020

Copyright ©2020 Rockwell Automation, Inc. All Rights Reserved. Printed in USA.



DIR10005708550 (Version 01)